



SAMSUNG

Enterprise IP Solutions

OfficeServ

User Guide
for
Large LCD Phones:
ITP-5012L
DS-5012L



TELECOMS



Publication Information

Samsung Telecoms reserves the right without prior notice to revise information in this publication for any reason.

Samsung Telecoms also reserves the right without prior notice to make changes in design or components of equipment as engineering and manufacturing may warrant.

Disclaimer

Samsung Telecoms is not responsible for errors or problems arising from customers not installing, programming or operating their Samsung systems as described in this manual.

Copyright 2004 Samsung Telecoms (UK) Limited

All rights reserved. No part of this manual may be reproduced in any form or by any means – graphic, electronic or mechanical, including recording, taping, photocopy or information retrieval system – without express written permission of the publisher of this material.

Part No.: 18730

Version 1.0

EU Declaration of Conformity (RTTE)

Samsung Electronics Co., Ltd.

259 Gongdan-Dong, Gumi-City Kyungbuk, Korea, 730-030

(factory name, address)

declare under our sole responsibility that the product

Digital Keyphone System "iDCS500 / OfficeServ500"

to which this declaration relates is in conformity with

RTTE Directive 1999/5/EC (Annex II)
Low Voltage Directive 73/23/EEC
EMC Directive 89/336/EEC:92/31/EEC



By application of the following standards

.....
RTTE: TBR4: November 1995 incorporating TBR4/A1: December 1997
.....

LVD: EN60950: 2000 (IEC 60950, Third Edition, 1999)
.....

EMC: EN55022 : 1998, EN61000-3-2:1995 Inc A1/A2:1998 + A14:2000*,
.....

EN61000-3-3:1995, EN61000-4-2:1995 98, EN61000-4-3:1996,
.....

EN61000-4-4:1995, EN61000-4-5:1995, EN61000-4-6:1996,
.....

EN61000-4-11:1994, AS/NZS3548:1995
.....

(Manufacturer)

Samsung Electronics Co., Ltd
259, Gongdan-Dong, Gumi-City
Kyungbuk, Korea, 730-030

2003-05-19 TE Jang

(place and date of issue)



Tae-eok Jang / General Manager

(name and signature of authorized person)

(Representative in the EU)

Samsung Electronics Euro QA Lab.
Blackbushe Business Park
Saxony Way, Yateley, Hampshire
GU46 6GG, UK

2003-05-18 IS Lee

(place and date of issue)



In-Seop Lee / Manager

(name and signature of authorized person)

About This Guide

This User's Guide provides instructions for using Samsung's latest ITP-5012L Internet Phone and DS-5012L Digital Phone in conjunction with the Samsung Enterprise IP Solutions OfficeServ telephone system. Both are large LCD phones which display icons and menus to allow fast and easy selection of functions and features.

You are shown how to install your phone, how to configure it to work correctly and how to operate it. Take time to study this guide and familiarise yourself with the operation of your phone—and the benefits the new IP technology can provide if using the Internet Phone. Keep the guide in a convenient place by the phone and refer to it whenever necessary.



Safety Tips

The ITP-5012L IP phone is supplied with an AC power adapter and this adapter must be used.

If an alternative power adapter is used, this may result in serious damage and will void the warranty.

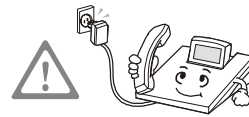

Do not put objects that contain water—such as vases, cups, cosmetics, and medicines—near the phone.

Moisture in the phone can cause fire and electric shocks.

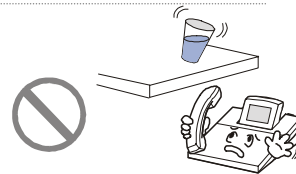

Do not install the phone on an unstable surface or in direct sunlight.

May cause severe damage to parts of the phone

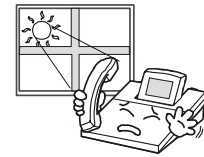

Do not place the phone in an area which is prone to dust or fluctuating temperatures.

May cause a fire or electric shocks.



Do not install the phone near a heat source (electric fire, radiator, etc.)

May cause a fire or electric shocks.



Do not use or store inflammable solvents or materials near the phone.

May cause a fire or electric shocks.



If the phone makes unexpected noises, odd smells or smoke, immediately unplug the phone and call your dealer.

May cause a fire or electric shocks.





CAUTION

ITP-5012L—Take care not to connect the network (LAN) cable to the PC connector on the phone.

If the LAN cable is connected to the PC connection jack, both telephone and PC communications will be lost.

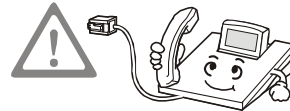

Use a soft dry cloth to clean the phone.
Do not use any chemical solvents such as wax, benzene, alcohol, thinner, mosquito spray, aerosol, lubricant, or detergent to clean your phone.

The use of chemicals on the phone may cause fading, discoloration or damage.

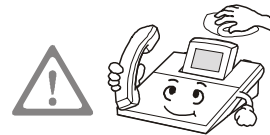

Do not place heavy items on top of the phone.

May cause damage .

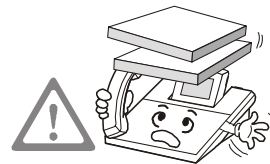

Do not attempt to dismantle or repair the phone yourself.

If repair is needed, contact your dealer.



Contents

ABOUT THIS GUIDE	i
SAFETY TIPS.....	i
INSTALLING THE PHONE	1
ITP-5012L Internet Phone.....	1
1. Checking Components.....	1
2. Assembling the Phone	3
DS-5012L Digital Phone.....	5
1. Checking Components.....	5
2. Assembling the Phone	7
3. Supporting the Samsung Network SYNC Program	9
CONFIGURING THE IP PHONE.....	10
1. Entering the Environment Setup Mode	10
2. Network Settings	13
3. Load & Upgrade Settings	15
4. Setting System Authentication Information	17
5. Verifying Settings	18
6. Exiting Setup	19
THINGS YOU SHOULD KNOW	20
1. About Stations and Central Office Lines.....	20
2. Introduction to the Main Screens.....	21
Background Screen	21
AOM Screen	21
Fixed Feature Menu Screen	22
Executive Status Display	22
Navigation Menu Screen	23

3. Using the AOM Screen.....	24
4. Using the Fixed Feature Menu Screen	24
5. Using Feature Dialling Codes	26
6. Entering Numbers & Characters	28
7. Volume Adjustment.....	32
Adjusting Handset Volume.....	32
Adjusting Speaker Volume	33
Adjusting Ring Volume.....	33
8. Signal Tones.....	34
9. Changing Dial Tone	35
10. Phone Status Indicator	35
11. Button LEDs	36
MAIN FEATURES	37
1. Overview	37
2. Layout of the Phone	42
ANSWERING CALLS	46
1. Before Answering a Call	46
2. Answering an Intercom Call.....	47
Automatic Answering Mode	48
Voice Announce Mode	49
3. Answering an Outside Call.....	50
Automatic Answering Mode	51
Universal Answer for Outside Calls	52
4. Other Call Functions	53
Station Call Pickup.....	53
Group Call Pickup.....	54
Answering a Waiting Call	55

MAKING CALLS 57

- 1. Before Making a Call 57**
- 2. Making an Intercom Call 59**
 - Busy Station Callback 60
 - Busy Station Camp-On 62
 - Calling the System Operator..... 63
- 3. Making an Outside Call..... 63**
 - Redial Number 64
 - Automatic Redial..... 65
 - Setting a Callback on an Outside Line..... 67
 - Making a New Call..... 69
 - Using Authentication & Account Codes 69
 - Saving a Telephone Number 71
 - Redialling a Saved Number 71
- 4. Other Call Functions 72**
 - Last Number Redial 72
 - Calling From Lists of the Most Recent Called
Numbers or Incoming Calls 73
 - Dialling from the Recent Call Log 73
 - Speed Dialling 74
 - Dialling from Directory Names 75

HANDLING CALLS 77

- 1. Intercom Calls 77**
 - Hold an Intercom Call 77
 - Mute Your Phone 78
- 2. External Calls 78**
 - Hold an External Call 79
 - Hold an External Call & Make an Intercom Call 80
 - Call Transfer..... 81
 - Call Parking..... 82

Transfer Calls to Voice Mailbox	83
3. Intercom & External Calls.....	84
Conference Calls	84
Load Group for Conference	86
CONVENIENCE FEATURES	87
1. Call Forwarding.....	87
Forward All Calls	87
Forward Busy	88
Forward No Answer	88
Forward Busy/No Answer	89
Forward Follow Me	89
Forward DND	90
Cancel Call Forwarding	91
2. Do Not Disturb (DND).....	91
Setting / Cancelling DND	91
3. Paging	93
Internal Page.....	93
External Page	94
All Page	96
Meet Me Page.....	97
Call Park and Page.....	99
Page Pickup.....	100
4. Off-Hook Voice Announce (OHVA)	101
Make OHVA	101
Answer OHVA	102
Cancel OHVA.....	102
Reject OHVA.....	103
Block OHVA	103
5. Messaging	104
Leaving a Message Waiting Indication	104

Verify, Return or Delete an Indication	105
Programmed Messages.....	107
6. Executive/Secretary Hot Line.....	109
Executive Status Display	109
Call Transfer from Secretary to Executive	110
Executive/Secretary Message	111
7. In/Out of Group	113
8. Group Listening.....	114
9. Caller ID (CID) Presentation	115
Saving Caller Number.....	115
Dialling a Saved Caller Number.....	116
Storing a Caller Number as a Speed Dial Number	116
Viewing the CID of Calls Parked or On Hold	117
10. Call Duration Display	118
11. Door Phone Related Features.....	118
Answering the Door Phone.....	118
Calling the Door Phone.....	119
12. Background Music	120
NAVIGATION MENUS.....	121
1. Navigation Buttons.....	121
Menu Button.....	121
Send Button	122
Enter Button	122
Direction Buttons	122
Cancel Button	123
End Button	123
2. Entering Menus.....	123
Selecting Menus	123
3. Phone Book.....	124

Search by Speed Dial Number Location.....	125
Search by Name	126
Search by Number.....	127
Search by Group.....	128
Search by Time	129
Recently Called Numbers	129
Recent Caller Numbers	130
Registering New Numbers.....	131
Editing Groups	132
Deleting All Telephone Numbers.....	133
Checking Your Own Extension Number	134
4. E-Diary.....	135
Wakeup Call.....	135
Alarm Clock.....	136
Daily Planner.....	137
Memo Pad.....	139
Calculator	140
World Time.....	141
D-DAY Plus	142
Unit Conversion	143
5. Messages.....	144
Received Messages	145
Sent Messages	148
Draft	151
6. Volume Adjustment.....	153
Selecting a Ring Type.....	153
Ringer Volume	154
Off-Hook Volume.....	155
Handset Volume	156
Speaker Volume.....	156
Background Music (BGM) Volume.....	157

Page Volume.....	158
7. Call Forwarding.....	158
8. Configuration	159
Changing Your Password	160
Locking Your Phone.....	160
Setting the Answer Mode.....	161
Setting the Boss Answering Mode.....	162
Phone Language	163
Setting the Type of Caller ID (CID) Display	164
Setting Absence Messages	164
Displaying Internal Calls	165
Dial Mode	166
Switching Station Features On & Off	167
9. My Phone	168
Select the Background Screen	169
Entering Your Name.....	169
Network Information.....	170
Viewing Status Information	170
Enbloc Timeout	171
Privacy Option.....	172
Reset Configuration.....	172
Version Information.....	173

Installing the Phone

ITP-5012L Internet Phone

1. Checking Components

You should have received the following items. If any are missing or damaged, contact your dealer.

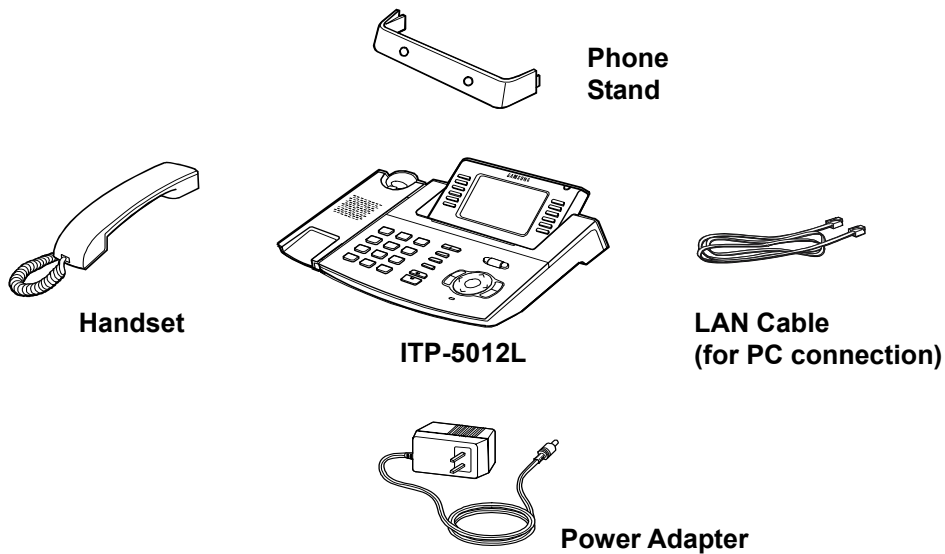

Base of Phone

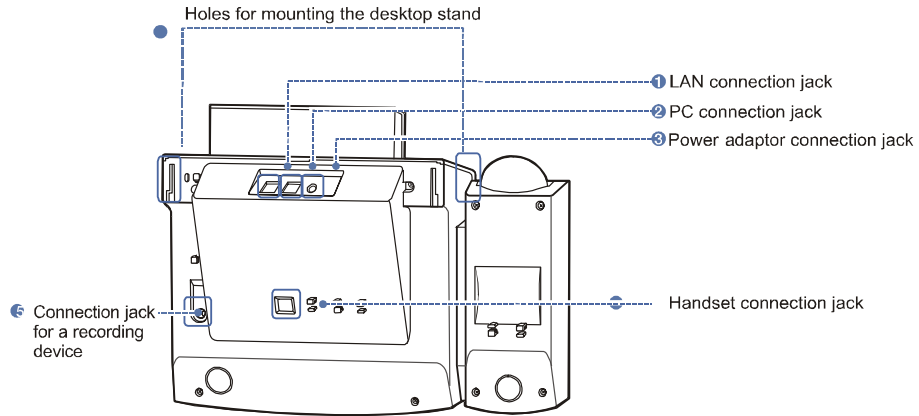

LAN connection jack: ①

For connecting the LAN cable from the network.

PC connection jack: ②

For connecting the LAN cable from a PC's network card.

Power adapter connection jack: ③

For connecting the power adapter cable.

Handset connection jack: ④

For connecting the handset cord (jack marked with  symbol).

Connection jack for a recording device: ⑤

For connecting a recording device.

Holes for mounting the phone stand: ⑥

For inserting the phone stand when used as a desk phone.

2. Assembling the Phone

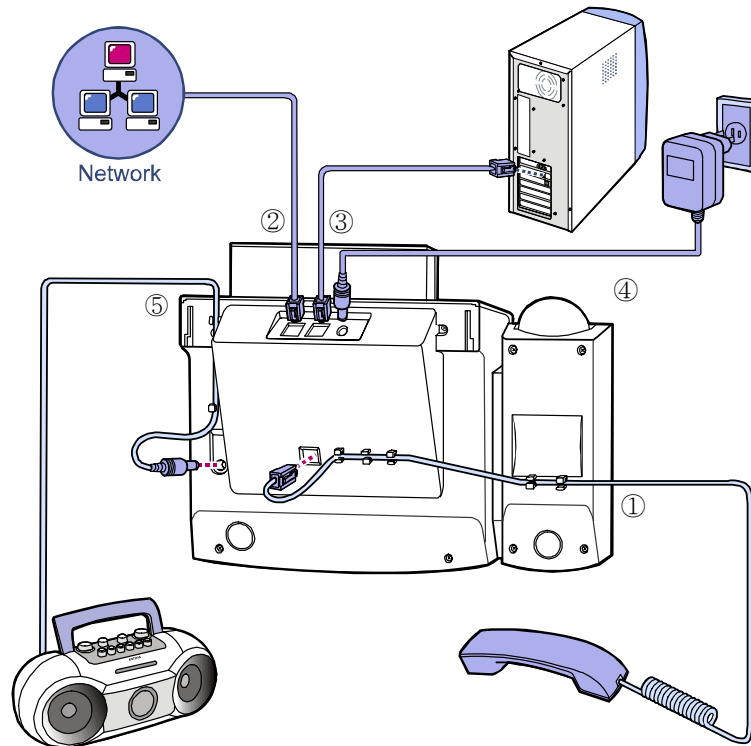

Connecting Cables to the Phone

1. Connect the handset to the handset connection jack ().
2. Connect the LAN cable from the network to the LAN connection jack.

3. Connect the LAN cable from the PC's network card to the PC connection jack.
4. Connect the power adapter to the power adapter jack. (**Do not** connect the power adapter to the mains outlet yet, or if you do, ensure that the power is not switched on.)
5. Connect any recording device to the recording device jack (REC.) (The recording device can record phone conversations.)

Using the Phone Stand

If the phone is to stand on a desk, insert the phone stand into the two side holes located on the base and slide it upward, as shown.

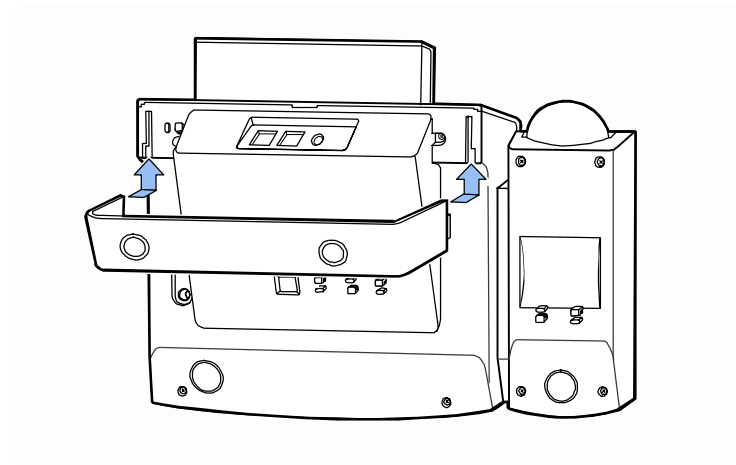

Now skip to the section **Configuring the IP Phone** to configure the working environment for your phone.

DS-5012L Digital Phone

1. Checking Components

You should have received the following items. If any are missing or damaged, contact your dealer.

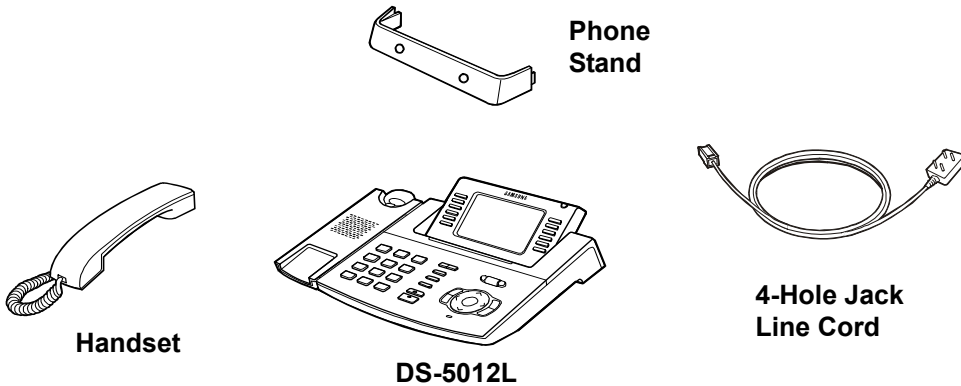

Base of Phone

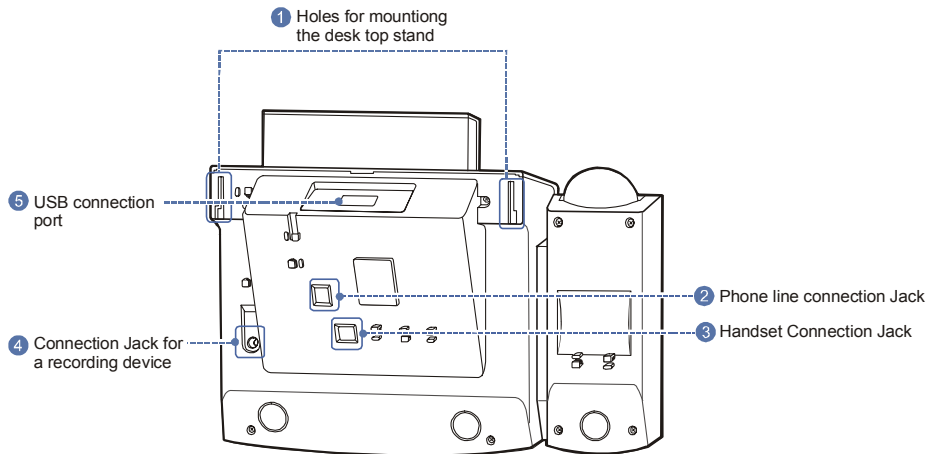

Holes for mounting the desktop stand: ①

For mounting the phone stand.

Phone line connection jack: ②

For connecting the line cord.

Handset connection jack: ③

For connecting the handset cord (jack marked with the  symbol).

Connection jack for a recording device: ④

For connecting a recording device.

USB connection port: ⑤

For connecting PC to the phone.

2. Assembling the Phone

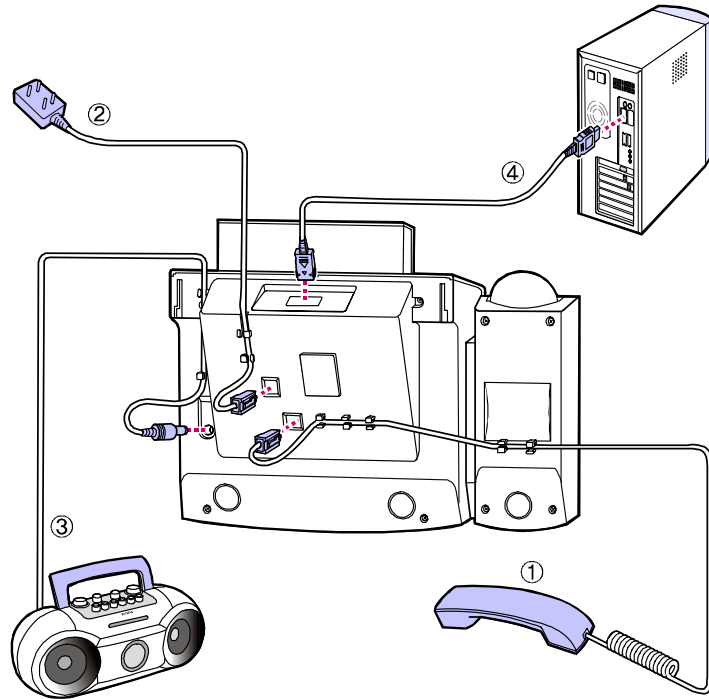

Connecting Cables to the Phone

1. Connect the handset to the handset connection jack ().
2. Connect the line cord to the phone line jack.

3. Connect any recording device to the recording device jack (REC.) (The recording device can record phone conversations.)
4. To use the Samsung Network SYNC program, connect one end of a data cable (not supplied) to the USB connection port on the phone and connect the other end to the USB port on the PC.
 - Refer to *Supporting the Samsung Network SYNC Program*, below.

Using the Phone Stand

Insert the phone stand into the two side holes located on the base and slide it upward, as shown.

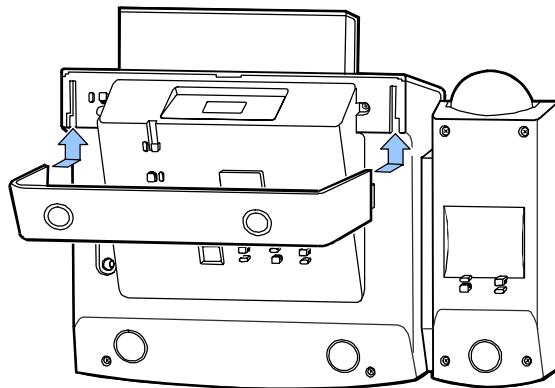

To familiarise yourself with the features of your phone, refer to **Things You Should Know** and **Main Features**.

3. Supporting the Samsung Network SYNC Program

You can edit telephone number data from the Samsung Network SYNC program as needed and download the data to the phone. The Samsung Network SYNC installation program can be downloaded from the Samsung Telecoms (UK) website, shown below. If your web browser is already open, right click on the link and select to open the link in the browser:

<http://www.samsung-telecoms.co.uk>

You are also provided with details of how to use the program.

Connect the data cable as described above and start the program. When finished, exit the program and disconnect the cable.

Configuring the IP Phone

This section describes the procedure for setting the ‘user environment’ after installing your ITP-5012L IP phone. You also need to do this if the phone system to which your phone is connected has been changed or re-initialised,

Before beginning the procedure, make sure the power to the phone has been switched off.

1. Entering the Environment Setup Mode

Press and hold down the **[Menu]** button and turn on the power to the phone.

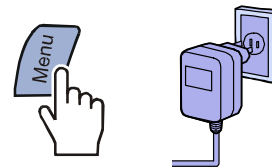

The environment setup menu appears on the LCD screen.

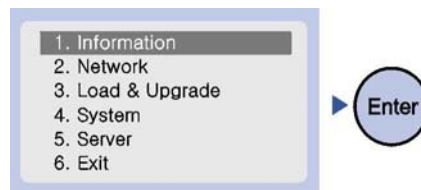

Setup Menu Structure

The setup menus are as follows.

1. Information	<ol style="list-style-type: none">1. Version2. Network3. Load Option4. MAC address
2. Network	<ol style="list-style-type: none">1. Mode2. IP*3. Netmask4. Gateway* <p>(* Items 2 to 4 are only displayed when setting Manual IP)</p>
3. Load & Upgrade	<ol style="list-style-type: none">1. Load Option2. Upgrade Program3. Upgrade Bootrom4. Format
4. System	<ol style="list-style-type: none">1. Password (*Not Used)
5. Server	<ol style="list-style-type: none">1. Server IP2. ID3. Password
6. Exit	

How to Edit the Setup Menus



Moving Between Menus

Press the [^] and [V] buttons to move to a menu and press the [Enter] button, OR

Press the number of the menu using dial buttons [0] to [9], or

Press the [Menu] button to move to the environment setup menu and use the [^] and [V] buttons to move to other menus and select

Entering Numbers and Characters

Enter a number or character using the dial buttons [0] to [9].

Press the [*] button to enter a full stop.

(Refer to *Entering Numbers and Characters* in the **Things You Should Know** part of this guide for how to enter characters.)

Deleting Entries

Press the [←] button or [Cancel] button to delete entries by moving the cursor to the left.

Saving Information

Press the [Enter] button to save any information you type in.

Cancelling Settings

Press the [End] button to move back to the previous menu without saving information you just typed in.

2. Network Settings

1. Use the [▲] and [▼] buttons to move to the **[2. Network]** menu and press the **[Enter]** button.

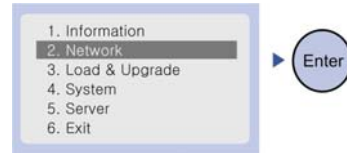

2. Move to the **[1. Mode]** submenu and press the **[Enter]** button.



3. Select the **[1. Manual IP]** menu to manually enter the IP address.
OR
Select **[2. DHCP]** to let the system automatically set the IP address.
(The IP Address, Subnet Mask, and Gateway values are automatically set and are not displayed on the LCD screen.)
OR
Select **[3. PPPoE]** to use broadband such as ADSL. (In this case, you will need to enter the ID and password given to you by your Internet Service Provider.)



The screen displays your selection (e.g. Manual IP SELECTED) for a few seconds

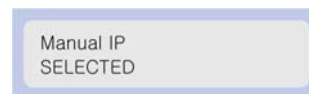

The next menu to appear will display different options depending on your selection. These are described next. If you selected **[2. DHCP]** your settings are automatically completed and you can proceed to *Load & Upgrade Settings*, below.

Setting Manual IP

If you selected the **[1. Manual IP]** menu you see the following options:

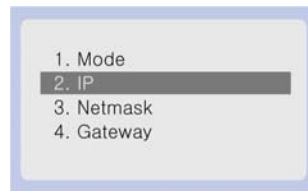

1. Select **[2. IP]** to display the phone's current IP address. (No address is displayed if an IP address has not yet been set.)



Use the dial buttons [0] to [9] and [*] to enter a new IP address, and press the **[Enter]** button.

(Note: Take care not to enter a duplicate IP address as the network does not support redundant IP addresses.)

2. Select **[3. Netmask]** to display the current Netmask address. To change the Netmask address, enter a new value and press the **[Enter]** button.



3. Select **[4. Gateway]** to display the current Gateway address. To change the Gateway address, enter a new value and press the **[Enter]** button.



Your network settings are now complete.

3. Load & Upgrade Settings

1. Use the **[^]** and **[v]** buttons to move to the **[3. Load & Upgrade]** menu and press the **[Enter]** button.

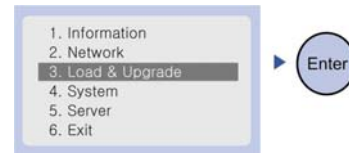

2. Select **[1. Load Option]**

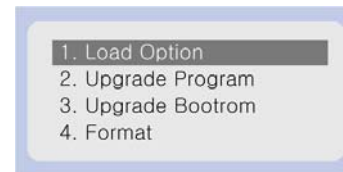

3. Select **[1. File System]** to download programs saved in the internal flash memory.
OR
Select **[2. TFTP down run]** to download programs saved in the TFTP server to the RAM memory of the IP phone.

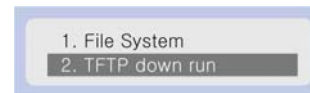

4. Select the **[2. Upgrade Program]** menu to upgrade the program.

Enter the IP address of the TFTP server from which the program should be downloaded.

Press the **[Enter]** button to start the download.

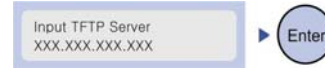

5. The **[3. Upgrade Bootrom]** menu is used for upgrading the Bootrom.

Enter the IP address of the TFTP server from which the Bootrom program should be downloaded, and press the **[Enter]** button.

- The IP phone is rebooted after downloading the Bootrom program and the Environment Setup Main Menu appears. You don't need to press the [Menu] button.



6. The **[4. Format]** menu is used to delete previously saved programs. Check if the program needs to be deleted before using this function.



After formatting the phone, download a new program through the [2. Upgrade Program] menu.

4. Setting System Authentication Information

This function is used to set the IP address of the system connected to the IP phone, and the authentication ID and password of the IP phone. The ID and password are used only when setting up the IP phone and are not required while operating it.

1. Use the [^] and [v] buttons to move to the **[5. Server]** menu and press the **[Enter]** button.

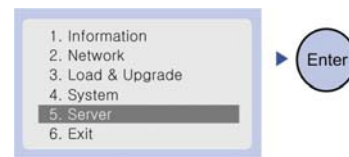

2. The submenus are displayed.
 - If the system is set to request the ID and password of the IP phone, **[2. ID]** and **[3. Password]** should be entered.



3. The **[1. Server IP]** menu is used for verifying or changing the IP address of the system. Verify the current IP address of the system. To change the IP address, enter a new address and press the **[Enter]** button.



[2. ID] and **[3. Password]** are user information required for connecting to the system.



Contact the system manager for the correct ID and password.



The ID comprises a maximum of 16 characters and numbers. The password is a maximum of eight numbers and is displayed as asterisks (*) when entered.

5. Verifying Settings

You can verify the settings after setup and make any changes required.

1. Use the [^] and [v] buttons to move to the **[1. Information]** menu and press the **[Enter]** button.

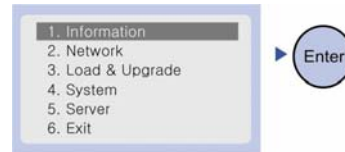

2. The submenus are displayed.
Select each menu and verify the settings. Check especially the **[2. Network]** menu settings before using the phone.

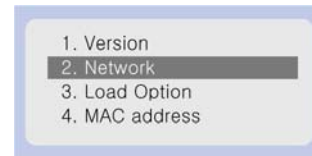

6. Exiting Setup

Exit the environment setup operation and reboot the system.

1. Return to the environment setup menu, select the **[6. Exit]** menu and press the **[Enter]** button.

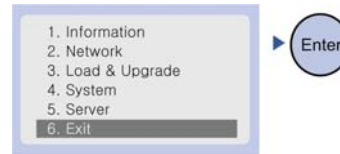

2. The settings are saved and the phone reboots.

To familiarise yourself with the features of your phone, refer to **Things You Should Know** and **Main Features**.

Things You Should Know

1. About Stations and Central Office Lines

A **station** is a telephone in the office that allows you to make calls to other stations connected to the telephone system in the office.

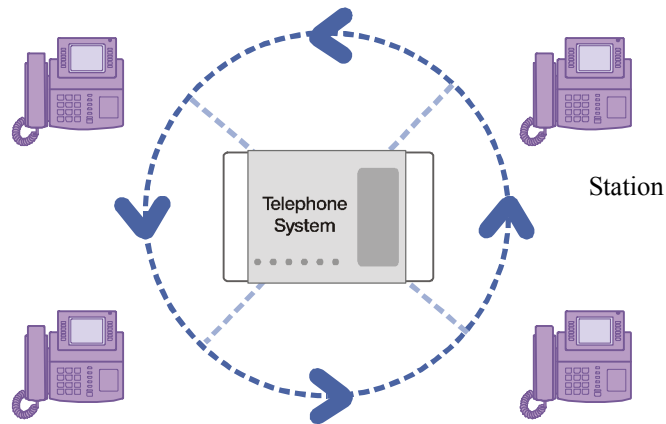

A **trunk (central office) line** is directly connected to the switching system of your phone company. It carries telephone calls from stations to phones outside the office, and incoming calls from outside to stations in the office.

2. Introduction to the Main Screens

The main screens displayed on the LCD of the phone are: the AOM screen, the Fixed Feature Menu screen, the Background screen, the Executive Status Display and the Navigation Menu screen. For some screens you will see a different display depending on whether you are busy on a call or the phone is idle (in **standby mode**).

Background Screen

This is the default screen that appears when in standby mode. You can change the Background screen using the 'My-Phone' feature in the **Navigation Menu Screen** (below).

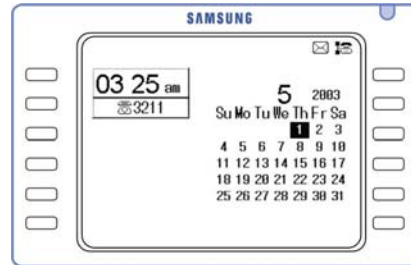

AOM Screen

The AOM screen appears when the **[Screen]** button is pressed *once* when in standby mode or during a call. The various features set up in the telephone are displayed.



You select features by pressing the **[Selection]** button next to the feature.

Fixed Feature Menu Screen

There are two types of Fixed Feature Menu Screen: a screen that appears during a call, and another that appears when the **[Screen]** button is pressed *twice* when in standby mode. The selectable features are chosen from menus by pressing the **[Selection]** button next to each menu.

Example of the Fixed Feature Menu screen during a call

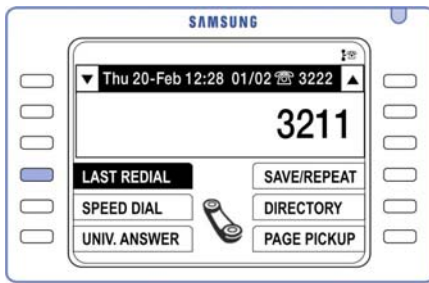

Example of the Fixed Feature Menu screen that appears when the [Screen] button is pressed when in standby mode

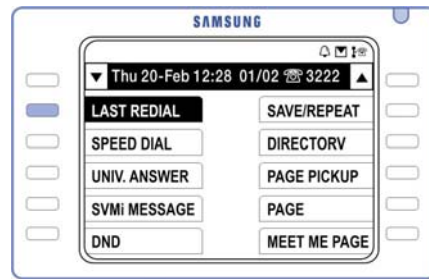

Executive Status Display

If the Executive/Secretary function is set in the system, this screen appears when the **[Screen]** button is pressed *three times* while in standby mode,

A secretary can set the executive status appropriate to each situation.

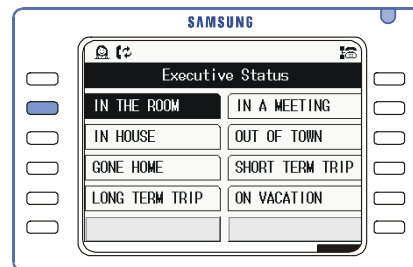

Navigation Menu Screen

This screen appears when the **[Menu]** button on the Navigation buttons is pressed when in standby mode.

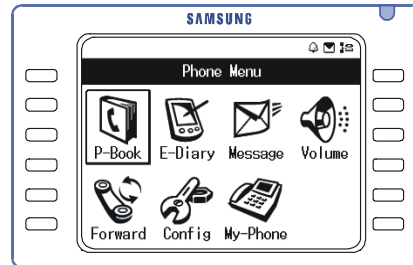

The Phone Book, Electronic Diary, Message, Volume, Forward, Configuration and My Phone features are displayed as icons.



When the phone is in standby mode, the AOM screen, Fixed Feature Menu screen, Executive Status Display and Background screen are displayed consecutively whenever the [Screen] button is pressed. Keep pressing the [Screen] button until the desired screen appears.

The menus displayed on the AOM screen depend on what is set up in the phone system.

3. Using the AOM Screen

Features set up in the system are displayed as menus on this screen. You select features by pressing the **[Selection]** button for each.

1. When the telephone is in standby mode or during a call, press the **[Screen]** button until the required AOM screen is displayed.



2. Press the **[Selection]** button for the desired feature. For example, if you want to use the Message feature, press the **[Selection]** button for **[MESSAGE]**.

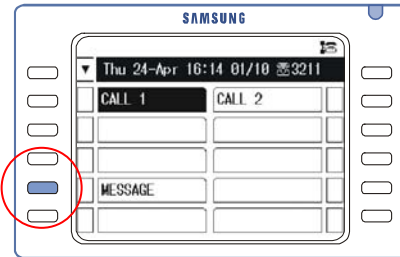

4. Using the Fixed Feature Menu Screen

Features that can be used during a call or when in standby mode are displayed on the Fixed Feature Menu screen. You select a feature by pressing the **[Selection]** button next to the feature. This screen appears automatically when you are on a call.

1. If the telephone is in standby mode, press the **[Screen]** button until the Fixed Feature Menu screen is displayed.



2. Press the **[Selection]** button for the desired feature from the display.

For example, if you want to use the Last Redial feature, press the **[Selection]** button for **[LAST REDIAL]**.

Moving the **Scroll** key up and down scrolls through long text displays on the Fixed Feature Menu screen. You can move between menus using either the Scroll key or Navigation direction buttons.

The menus displayed on the Fixed Feature Menu screen depend on what is set up in the system. If there are more features than will display on the screen, use the Scroll key or Navigation buttons to scroll to the other pages of features—or use the [Selection] buttons for the ▼ and ▲ arrows to move to the next page or previous page of features, respectively.

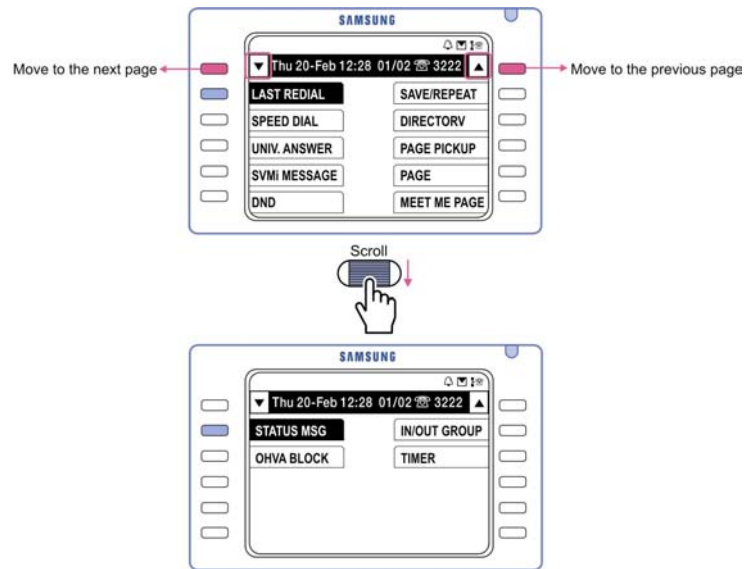

5. Using Feature Dialling Codes

You should now be familiar with using the menu screens to select features. However, the phone system also provides feature codes which can be dialled to select features such as forwarding calls, sending messages, paging, etc. The table below lists the dialling codes for each function. You can find out more about all these features by referring to the relevant sections in this guide. Use this table for quick reference.

10 + ext no	Retrieve parked calls	55 + 3	Page internal zone 3
11	Put calls on and take calls off hold	55 + 4 55 + 5	Page internal zone 4 Page external zone 5
12 + ext no	Retrieve calls on hold at another extension	55 + 6 55 + 7	Page external zone 6 Page external zone 7
13	Door lock release	55 + 8	Page external zone 8
16 + spd no	Make speed dial calls	55 + 9	Page all external zones
17	Redial saved number	55 + *	Page all zones 1–8
19	Last number redial	56	Meet Me Page Answer
2xx(x)	Extension numbers	57	Alarm sensor clear
3xx(x)	Extension numbers	58	DISA alarm clear
400	Cancel Do not Disturb	59	Walking class of service
401	Set Do Not Disturb	60	Set call forward
41	Set Message No Ring	600	Cancel all call forwarding
42 + ext no	Cancel message	601 + ext or grp no	Set Fwrd All Calls
43	Set/return messages	602 + ext or grp no	Set Fwrd Busy
44	Busy extension/line callback	603 + ext or grp no	Set Fwrd No Ans
45	Busy extension camp-on	604 + ext or grp no	Set Fwrd Busy/No Ans
46	Set up a conference	605 + ext or grp no	Set Fwrd DND
47	Enter account code	606 + ext or grp no	Set Fwrd Follow Me
48 + msg no.	Set programmed station message	65 + ext no	Station (Directed) call pickup
49	Send flash to outside line	66 + grp no	Group call pickup
5xx(x)	Station hunt group	67	Universal Answer
54+zone	Meet Me Page	7xx(x)	Individual line numbers
55 + 0	Page all internal zones	8xx, 9	Trunk groups
55 + 1	Page internal zone 1		
55 + 2	Page internal zone 2		



These function codes are for a system set up with default values. If the codes have been changed for your system, see your system administrator for the correct values.

6. Entering Numbers and Characters

Using the dial buttons and Navigation buttons, you can easily enter and edit alphabetic characters, numbers and special characters on the LCD screen.

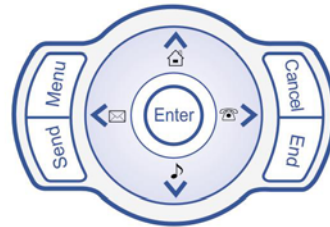

Selecting an Input Mode

When a screen appears for entering text or numbers, press the **[Menu]** button repeatedly until the desired input mode is selected. These modes are shown below.

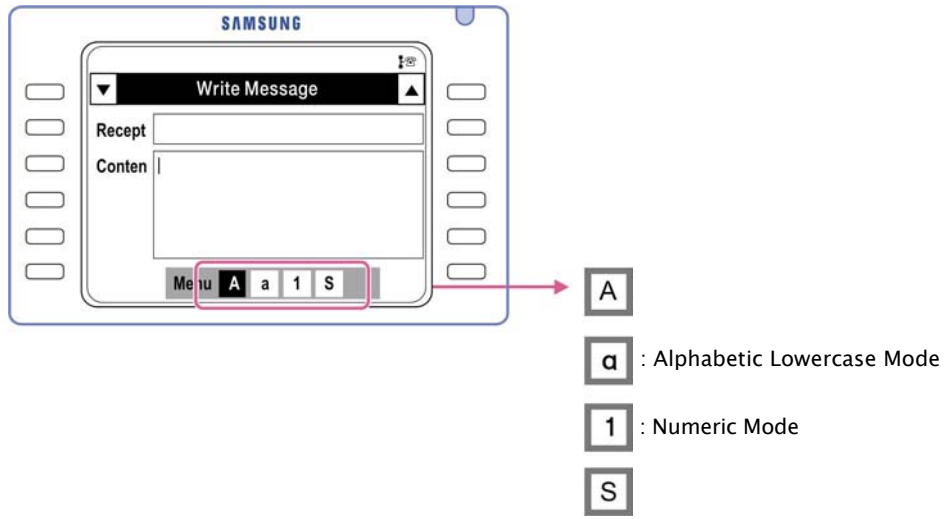















 NOTE The default input mode is set to alphabetic uppercase (English).

Entering Characters

1. Press the **[Menu]** button to select the alphabetic input mode (uppercase or lowercase).
2. Press the dial buttons to insert the desired characters (see table,below).

Characters are printed on some of the dial buttons. Each press of a different button automatically moves the cursor to the right. If the character you want to enter is the same as the previous character, press the **[>]** button on the Navigation buttons to move the cursor one space to the right before pressing the required dial button.

Dial Button	Character	Dial Button	Character	Dial Button	Character
			A B C		D E F
	G H I		J K L		M N O
	P Q R S		T U V		W X Y Z
	* / .		0		# @ -

- To select the character “R”, for example, you would press the dial button  three times.
- To enter more than one character from the same button, wait for about three seconds after entering a character and then press the button again.
- Press the [>] button to insert a space following a character.
- To insert a space between already entered characters, press the [<] and [>] buttons to move the cursor to the character after which the space is to be entered, and press the dial button .
- To delete a character, press the **[Cancel]** button. This deletes the character to the left of the cursor position. Press and hold down the **[Cancel]** button to delete all characters.

Entering Special Characters

1. Press the **[Menu]** button to select the special characters input mode.

The special characters that can be selected will be displayed in the lower part of the character input screen. If the character you require is not displayed, press the **[^]** and **[v]** buttons to scroll through other possible selections.

2. Press the **[<]** and **[>]** buttons to move the cursor and select the character, then press the **[Enter]** button.



1. Press the dial button **[0]** to insert a space.
2. Press the **[Cancel]** button to delete the character(s) to the left of the cursor. Press and hold down the **[Cancel]** button to delete all characters.

Entering Numbers

Press the **[Menu]** button to select the numeric input mode and then press the dial button displaying the required number.

7. Volume Adjustment

[▼Volume▲] buttons are used for adjusting the volume of the handset, speaker and ringing.

Adjusting Handset Volume

1. Lift the handset and make a call



2. Press the [Volume▲] button to increase the handset volume.

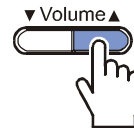

OR

Press the [▼Volume] button to decrease the handset volume.

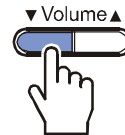

Adjusting Speaker Volume

1. Press the **[Speaker]** button and make a call.

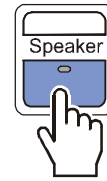

2. Press the **[Volume▲]** button to increase the speaker volume.

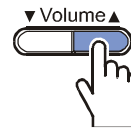

OR

Press the **[▼Volume]** button to decrease the speaker volume.

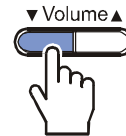

Adjusting Ring Volume

Here's how to adjust the ring volume while the phone is ringing. (Refer to 'Volume Adjustment' in **Navigation Menus** to adjust ring volume while the phone is in standby mode.)

1. To increase the ring volume, press the **[Volume▲]** button while the phone is ringing.

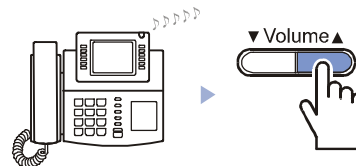

- To decrease the ring volume, press the **[▼Volume]** button while the phone is ringing.

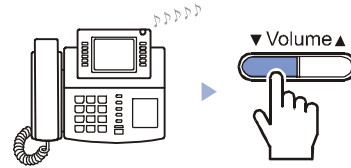

8. Signal Tones

The signal tones used by the telephone system are described in the following table. You will become familiar with these tones as you begin to use your phone.

Signal Tone	Meaning	Signal Interval*
Dial tone	(Steady tone) You can begin dialling	C.O. Line — Continuous Station — 1s ON/ 0.25s OFF
Ring-back tone	The station you dialled is ringing.	1s ON/ 2s OFF
Busy tone	The station you dialled is busy.	0.5s ON/ 0.5s OFF
Transfer tone	Your call is being held and you can dial another station.	0.1s ON/ 0.1s OFF
Confirmation tone	(Very short beeps) You have correctly set or cancelled a system feature.	0.05s ON/ 0.05s OFF

* The Signal Interval varies from country to country. These values are relevant for the UK.

9. Changing Dial Tone

To change mechanical (pulse) dial mode to electronic (tone) dial mode, press the [#] button before making a call. Every number dialled subsequently will be transmitted in tone mode.

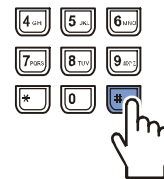

10. Phone Status Indicator

The status indicator turns on or off, and lights different colours, according to the status of the phone:

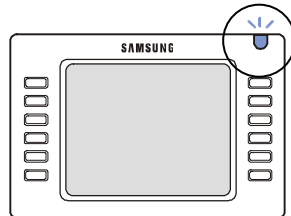

Status	Indication
Busy	Steady red.
Station Ring	Slow flashing red.
Trunk Line Ring	Slow flashing blue.
Recall Ring	Flashing pink.
Message Waiting	Flashing red.
DND Set	Slow flashing red.

11. Button LEDs

The [Transfer], [Hold] and [Speaker] buttons have an LED that turns on or off according to the phone status.

- [Transfer] button LED • • • • 

LED	Status
Steady red	Call Forwarding is set on station.

- [Hold] button LED • • • • 

LED	Status
Flashing red	Phone is locked for outgoing trunk line calls.
Steady red	Phone is locked for incoming and outgoing calls.

- [Speaker] button LED • • • • 

LED	Status
Steady red	Speakerphone is switched on.

Main Features

1. Overview

Network

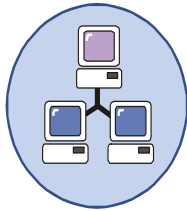

Network

The ITP-5012L IP phone represents a new era for voice and data communications. It uses Internet Protocol (IP) to send/receive voice and data. For voice communication, the phone uses your existing data network connection in your home or office. There is no need for a separate telephone connection, so reducing your communication infrastructure costs.

Large LCD Screen

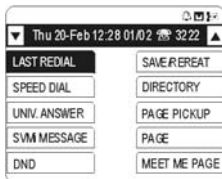

Displays various kinds of information. You simply press the related [Selection] button next to the item or menu. Provides easy search and selection of menus.

Navigation Buttons and Menus

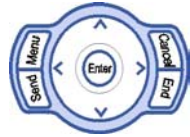

Allow you to select phone features such as the Phone-Book, E-Diary, Message, Volume, Forward, Config., and My-Phone. Features are shown as icons or menus on the LCD screen, just like a mobile phone. You can also use the buttons to scroll through long text displays on the LCD panel.

Speed Dialling

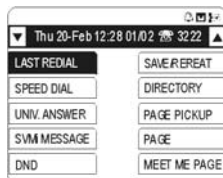

You can program the speed dialling feature with frequently used phone numbers. Pressing a single dial button will make a call to the speed dial number.

Pickup



You can answer a call to another extension from your own phone

Automatic Redial/Retry



If a called line is busy, you can reserve the automatic redial/retry function and waiting mode. The phone redials the called number automatically after the called party hangs up their phone.

Hold

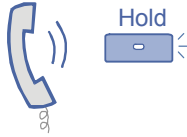

You can use the Hold or Transfer function when something urgently requires your attention or another call arrives at the phone. This button is used for briefly holding a call or transferring a call to another station.

Conference Calls



This button is used when multiple callers need to be connected simultaneously during a phone conversation. Up to five parties (you and four others) can be connected for a conference call.

Call Forwarding

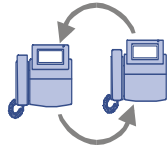

If you are unable to answer an incoming call, the call can be forwarded to another extension (always, or if you are busy on another call, or you do not answer).

Do Not Disturb (DND)

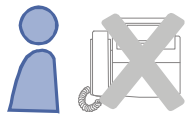

If you do not want any calls to ring at your phone, the DND feature can be set to block incoming calls.

Page



If you have an urgent announcement to make, you can page through the speakerphones of other extensions, or through external speakers, without calling individual extensions.

Executive/Secretary



When the Executive/Secretary button is pressed, an executive and secretary are connected. The secretary can use this feature to receive an incoming call and then simply forward it to the executive.

Caller ID

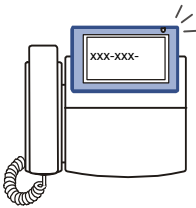

When there is an incoming call, the caller number and name can be displayed on the LCD screen. This feature is useful in situations where it is required to have this information before calls are answered.

2. Layout of the Phone

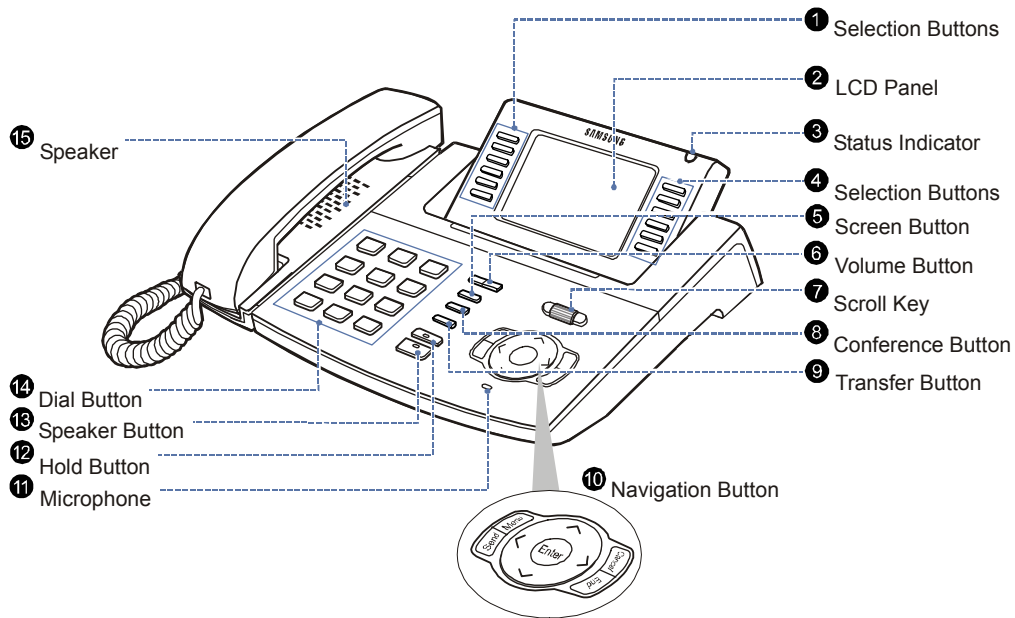

[Selection] buttons: ① and ④

For selecting items on the LCD panel.

LCD Screen: ②

The LCD screen comprises the status screen and the main screen.

- The status screen at the top of the LCD displays the set feature icons.

- The main screen displays selectable menus, call information and other messages.

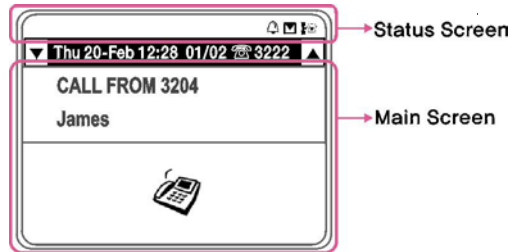

: Executive/Secretary	: Call Forward	: Phone Lock	: Answer Mode	: DND	: Headset Mode	: Group Listening	: Mute	: Alarm	: Message	: Network Connection Status

Status Indicator: 3

One of three colours (red, blue or pink) indicates the phone status. These are described in **Things You Should Know**.

Screen Button: 5

Select menus on the AOM (Add-On Module) screen, Fixed Feature Display or Executive Status Display. These are described in **Things You Should Know**.

Volume Buttons: ⑥

The ▲ and ▼ buttons adjust the volume levels for handset or speaker. These are described in **Things You Should Know**.

Scroll Key: ⑦

1. Scroll through long text displays on the LCD screen.
2. Can be used as an alternative to the Navigation buttons to quickly move between the items displayed in the phone menus.

Conference Button: ⑧

Connect multiple callers in a conference.

Transfer Button: ⑨

Transfer a call.

Navigation Buttons: ⑩

Use phone functions such as Phone-Book, E-Diary, Message, Volume, Forward, Config, and My-Phone via icons or menus on the screen.

Microphone: ⑪

Speak through the speakerphone instead of the handset.

Hold Button: ⑫

Briefly hold a call without hanging up.

Speaker Button: ⑬

Make a call through the speaker, without lifting the handset.

Dial Buttons: 14

Enter numbers and characters.

Speaker: 15

Hear a caller's voice or ring tones through the speaker instead of the handset.

ANSWERING CALLS

1. Before Answering a Call

Call answering methods and features are summarised in the following table. All are described in detail in this section.

Method/Feature	Intercom Calls	Outside Calls
Answering method	Handset or speakerphone	
Feature	- Answering an intercom call - Automatic Answering mode - Voice Announce mode	- Answering an outside call - Universal Answer
	- Station Call Pickup - Group Call Pickup - Answering a waiting call	

How Answer a Call

Using the handset

Lift the handset to answer a call.

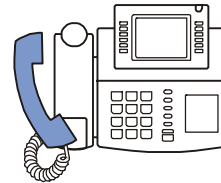

Using the speakerphone

Answer a call through the speakerphone without lifting the handset by pressing the **[Send]** button.



2. Answering an Intercom Call

How to answer a call from another station.

Using the Handset

1. When a call arrives, a call receipt message will be displayed on the LCD.



2. Lift the handset.

The call is automatically connected to your phone for you to answer.



3. Replace the handset when finished.

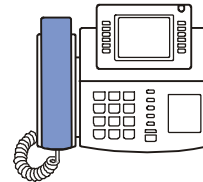

Answering Through the Speakerphone

Press the **[Send]** button without lifting the handset and answer the caller through the speakerphone.

(You can switch from the speakerphone to the handset by lifting the handset during the call, if required.)

Press the **[Speaker]** or **[End]** button to hang up the call on the speakerphone when finished.



To adjust the speaker volume while the phone is ringing, press the **[▼ Volume ▲]** buttons.

When a call arrives and a call receipt message appears on the LCD, but the phone does not ring, you should lift the handset to answer the call.

Automatic Answering Mode

How to answer a station call on a phone which has the Automatic Answering mode set.

- Refer to 'Setting the Answer Mode' in **Navigation Menus (Configuration)** for details of setting this mode.

When an incoming call arrives, you hear a short signal tone and the phone automatically answers the call.

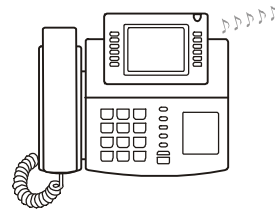

The speakerphone is turned on and you can speak hands-free. When the call is completed, press the **[Speaker]** or **[End]** button.

- Pick up the handset for privacy during the call.

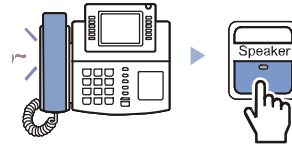

Voice Announce Mode

How to answer a station call on a phone which has the Voice Announce mode set.

1. When an incoming call arrives, you hear a short signal tone and then hear the caller's voice through the speaker.

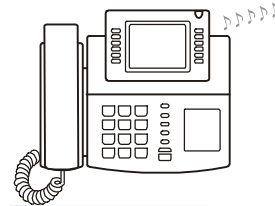

2. To answer the call, lift the handset or press the **[Send]** button. When the conversation is finished, press the **[Speaker]** or **[End]** button.

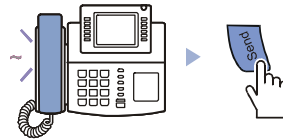

3. Answering an Outside Call

How to answer an outside (external) call.

Using the Handset

1. When a call arrives, a call receipt message is displayed on the LCD.



2. Lift the handset and the ringing call will be automatically connected to your phone.

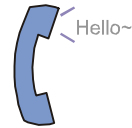

3. Replace the handset when finished.

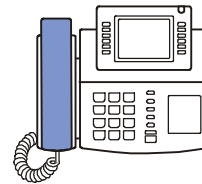

Answering Through the Speakerphone

Press the **[Send]** button without lifting the handset to answer the calling party through the speakerphone.

(You can switch from the speakerphone to the handset by lifting the handset during the call, if required.)

Press the **[Speaker]** or **[End]** button to hang up the call on the speakerphone when finished.



Press the [**▼** Volume **▲**] buttons while the phone is ringing to adjust the speaker volume.

When a call arrives and a call receipt message appears on the LCD, but the phone does not ring, you should lift the handset to answer the call.

Automatic Answering Mode

If the Auto Answer option for external calls is enabled on your phone, when an incoming call arrives you hear a signal tone of short interval and the phone automatically answers the call.

The speakerphone is turned on and you can speak hands-free.

When the call is completed, press the **[Speaker]** or **[End]** button.

- Pick up the handset for privacy during the call.

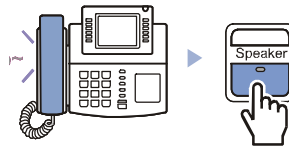
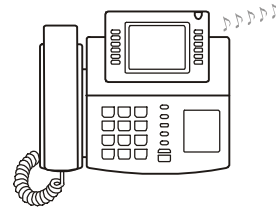

Universal Answer for Outside Calls

If an outside call arrives when there are no phone users at their desks to answer (for example, when night mode is set for the phone system), a Universal Answer device can be set to answer the call and ring through an external speaker for attention. (The Universal Answer feature does not apply to intercom calls.)

1. If an outside call arrives, it rings through an external speaker.

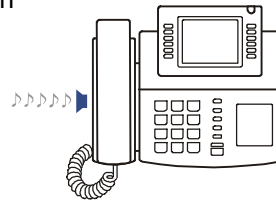

2. At a station, press the **[Screen]** button repeatedly until the Fixed Feature Menu screen appears.

- Or, press **[6][7]**, the function code for Universal Answer.



3. Press the **[Selection]** button for **[UNIV. ANSWER]** displayed on the Fixed Feature Menu screen.

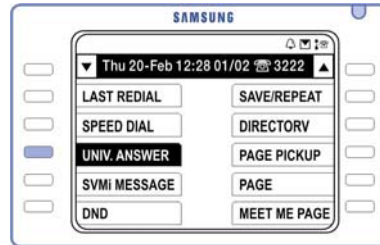

4. Lift the handset or use the speakerphone.

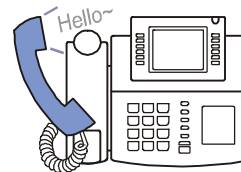



Check with the system administrator for what time night mode is set.

4. Other Call Functions

The following functions are available for answering both intercom and outside call.

Station Call Pickup

From your own phone, you can pick up a call ringing at another station (e.g. if there is no-one at that station to answer).

1. Lift the handset and listen for dial tone.

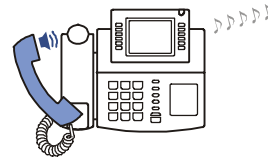

2. Press **[6][5]**, the function code for station call pickup.



3. Dial the extension number of the ringing phone and answer the call.

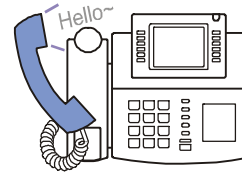

Station call pickup cannot be used to answer *recalls* to a station (except operator recalls), only *new* intercom or outside calls.

Group Call Pickup

Use the group call pickup feature to pick up a call at another ringing station when your phone and the ringing phone are part of the same pickup group.*

1. Lift the handset and listen for dial tone.

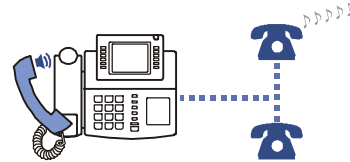

2. Press **[6][6]**, the function code for group call pickup.

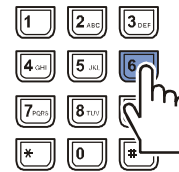

3. Dial your group number.

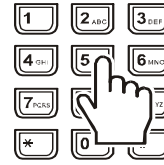

Your system administrator can tell you what your group number is.

Group call pickup cannot be used to answer *recalls* (except operator recalls) to a station, only *new* intercom or outside calls.

Answering a Waiting Call

If you are busy on a call and another call rings your phone, you hear a “camp-on” tone. The menu box for a waiting call will flash on the AOM screen so you can answer the new call.

1. Press the **[Screen]** button until the AOM screen appears.
 - If the Automatic Hold feature is set on your phone, the current call will be placed on hold automatically.



2. Press the **[Selection]** button for the station or outside call number flashing on the AOM screen.

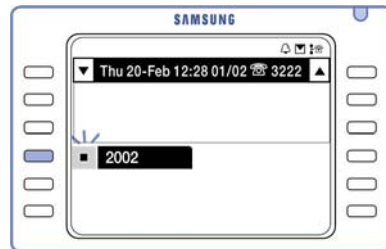

3. When a new incoming call arrives during the phone conversation, press the **[Hold]** button and then press the **[Selection]** button of the flashing number on the AOM screen.

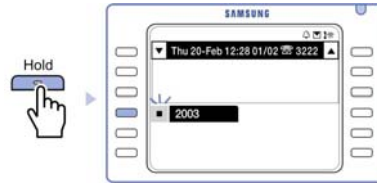

MAKING CALLS

1. Before Making a Call

Calling methods and features are summarised in the following table. All are described in detail in this section.

Method/Feature	Intercom Calls	Outside Calls
Calling method	Handset or speakerphone	
Feature	<ul style="list-style-type: none">- Making an intercom call- Busy station callback- Busy station camp-on- Calling system operator	<ul style="list-style-type: none">- Making an outside call- Redial- Automatic redial- Setting callback on external line- Answering external call-back- Call parking orbits- Using authentication codes / billing codes- Save dialled number- Calling the saved number
	<ul style="list-style-type: none">- Last number redial- Dialling from recent call log- Speed dialling- Dialling from directory names	

Important: The following procedures assume your phone is set for 'Enbloc' dialling, so you need to press the [Send] key after dialling a number. If your phone is set for 'Overlap' dialling, you do not need to press [Send].

How to Make a Call

Using the handset

Lift the handset to make a call.



Using the speakerphone

Make a call through the speakerphone without lifting the handset by pressing the **[Speaker]** button

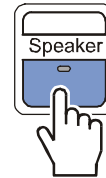

Hot keypad feature

If the Hot Keypad feature has been enabled on your phone, you do not need to lift the handset or press the [Speaker] button to begin dialling. Simply dial the number and press [Send]. The [Speaker] button LED lights and you can speak using the speakerphone or lift the handset.

2. Making an Intercom Call

How to make a call to another station.

Using the Handset

1. Lift the handset.

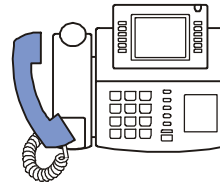

2. Dial the extension number of the station.

- Or, press the **[Selection]** button corresponding to the extension number shown on the AOM screen.



3. Press the **[Send]** button to begin dialling.

- If you hear a signal tone of very short interval, without the dial tone, the station you called is set for a voice announcement or automatic answer. Begin speaking immediately.

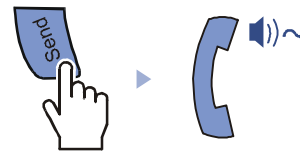

4. Begin speaking when the called party answers.



Calling Through the Speakerphone

Press the **[Speaker]** button and dial the extension number without lifting the handset.

Listen to the speaker for the called party to answer, and speak through the microphone.



(You can switch from the speakerphone to the handset by lifting the handset during the call, if required.)

Press the **[Speaker]** button to hang up the call on the speakerphone when finished.



Busy Station Callback

■ Setting a Callback

When you call another station and receive a busy signal, you can set a callback on that station. When it becomes free, it will automatically ring you back.

1. Press the **[Selection]** button for **[CALLBACK]** displayed on the screen.
 - Or, press **[4][4]**, the function code for a callback.



2. When you hear confirmation tone, replace the handset.

The screen will display a callback message.

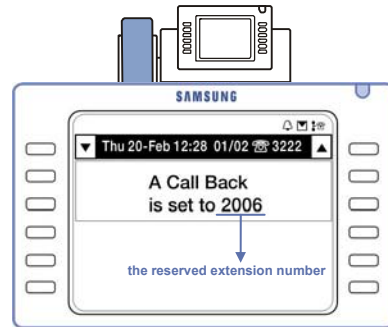

■ Answering a Callback

When the station on which you set a callback becomes free, your phone will ring.

1. Lift the handset.

You will hear ringing at the free station.

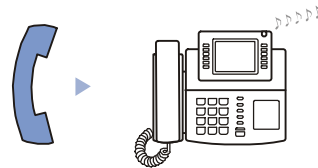

2. Begin speaking when the other party answers.

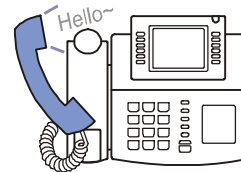



A callback will be cancelled if not answered within 30 seconds. After the call is finished, the callback reservation will be automatically cleared.

Busy Station Camp-On

When you call another station and receive a busy signal, but you do not want to wait for a callback, you can set a camp-on to the station. The called station is made aware that your call is waiting.

1. Press the **[Selection]** button for **[CAMP ON]** displayed on the screen.
 - Or, press **[4][5]**, the function code for 'camp-on' to an extension.



The called station will receive 'off-hook' ring tone repeated every few seconds to indicate that your call is waiting.

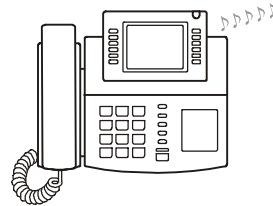

2. Wait for the called party to answer.





The called station must release its first call or put it on hold before answering your camped-on call.

Calling the System Operator

Dial **[0]** to call the system operator or group of operators.

If a specific operator needs to be called, dial that person's extension number.



3. Making an Outside Call

Using the Handset

1. Lift the handset, press **[9]** and then dial the external telephone number
 - Or, press the **[Selection]** button corresponding to the external number on the AOM screen to dial the number.

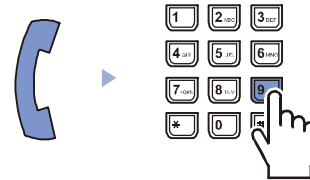

2. Press the **[Send]** button to begin dialling.



3. Begin speaking when the called party answers.

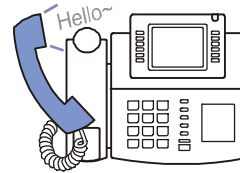

Calling Through the Speakerphone

Press the **[Speaker]** button and dial the extension number without lifting the handset.



Listen to the speaker for the called party to answer, and speak through the microphone.

(You can switch from the speakerphone to the handset by lifting the handset during the call, if required.)

Press the **[Speaker]** button to hang up the call on the speakerphone when finished.



Redial Number

You can redial the last external number you dialled.

1. With the phone is in standby mode, press the **[Screen]** button repeatedly until the Fixed Feature menu screen appears.
 - Or, press **[1][9]**, the function code for redialling, and press the **[Send]** button.



2. Press the **[Selection]** button next to **[LAST REDIAL]** displayed on the screen.

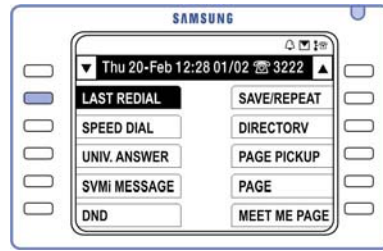

3. Begin speaking when the other party answers.

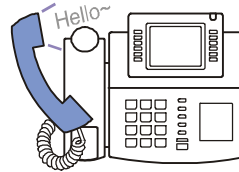

The Fixed Feature Menu screen will automatically display [Last Redial] during a call even if the [Screen] button is not pressed.

Automatic Redial

If the called external number is busy, the phone redials the called number automatically up to 99 times depending on what is programmed in the system. This is a useful when the called party is often busy at a service centre or call centre, for example.

1. On hearing busy tone, press the **[Selection]** button for **[RETRY]**.



The system will redial the same number automatically. You hear the dial tone through the speaker. The microphone is automatically disabled.

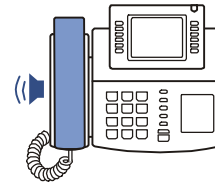

2. When the called party answers, either lift the handset or press the **[Speaker]** button or the **[Send]** button.
 - You must respond within 10 seconds. (An automatic redial will be cancelled if not answered within this time.)

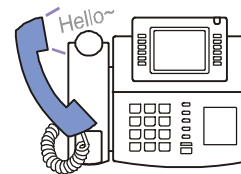

When you dial another number, the automatic redial is cancelled. To cancel redial, lift and replace the handset.

Setting a Callback on an Outside Line

If you receive a busy signal when selecting an outside line, this means that the line or group of lines is busy. The callback function allows a call to be placed in queue for a busy outside line.

■ Setting a Callback

1. When busy tone is heard, press the **[Selection]** button for **[CALLBACK]** displayed on the screen.
 - Or, press **[4][4]**, the function code for a callback.

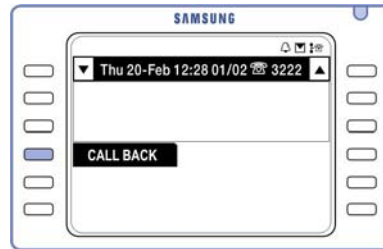

2. When you hear a confirmation tone, replace the handset.

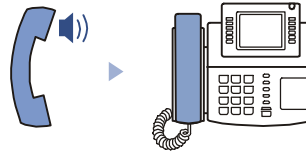

When the busy line becomes available, your phone will ring. Answer the callback as described next.



To cancel a callback: Follow the above procedure for setting a callback. At step 2, press the **[Hold]** button when you hear confirmation tone. Any set callback is cancelled.

■ **Answering a Callback**

1. Lift the handset.
You will hear dial tone.



Dial the outside telephone number and press the **[Send]** button.

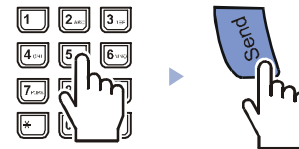

2. Begin speaking when the called party answers.

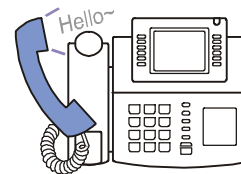

A callback will be cancelled if not answered within 30 seconds.

Making a New Call

You can disconnect your current call and make a new call on the same line.

1. After disconnecting your call, press the **[Selection]** button for **[NEW]** displayed on the screen.



2. Dial the new telephone number and press the **[Send]** button.

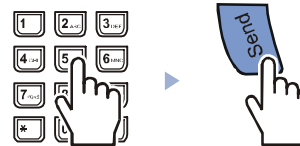

Using Authentication and Account Codes

Both Authentication (sometimes called Authorisation) Codes and Account Codes may be set up in your system. An authentication code may be required to allow you to make external calls. Account codes are used for billing purposes, so call charges can be assigned to specific accounts.

■ Using an Authentication Code

If you are asked for an authentication code before you are allowed to make an outside call, press the **[Selection]** button for **[AUTH]** displayed on the screen and select the relevant authentication code.

- Check with your system administrator if you don't know which code to select.



■ **Using an Account Code**

Account codes entered when making calls will be printed out on the detailed record of calls for your system, and the calls charged accordingly.

1. While making an outside call, press the **[Selection]** button for **[ACCT]** displayed on the screen.

- Or, press **[4][7]**, the function code for using an account code.

(Your call will not be interrupted.)



2. Enter the account code.



3. Press the **[Selection]** button for **[ACCT]** on the screen.



If you enter an incorrect account code, press the **[Selection]** button for the **[ACCT]** menu twice and enter the correct account code. Only the correct code will be printed out on call records. The use of authentication codes and account codes differs from system to system. Ask the system administrator for advice if necessary.

Saving a Telephone Number

When making a call, you can save the dialed number in order to be able to redial it.

Press the **[Selection]** button for **[SAVE/REPEAT]** before hanging up.

This will save the phone number called.

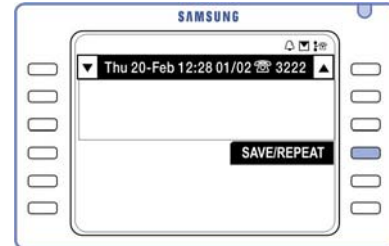

Redialling a Saved Number

You can redial a saved number at any time (but before you save another number).

Press the **[Selection]** button for **[SAVE/REPEAT]** on the Fixed Feature Menu screen.

- Or, press **[1][7]** the function code for redialling a saved number.



Remember: the saved number is stored in memory until you save another number.

4. Other Call Functions

The following functions are available for making both intercom and outside call.

Last Number Redial

Press and hold the **[Send]** button while in standby mode.

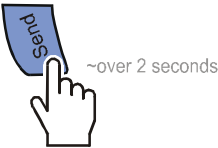

The phone redials the last telephone number that you dialed.

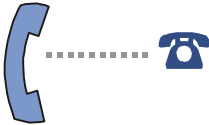

You can make a call through the speakerphone or handset. You can switch from the speaker to the handset simply by lifting the handset.

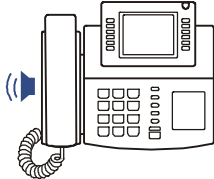

Calling From Lists of the Most Recent Called Numbers or Incoming Calls

The Navigation menus are used for this function. Refer to the *Recently Called Numbers* and *Recent Caller Numbers* sections in the **Navigation Menus (Phone Book)** part of this guide.

Dialling from the Recent Call Log

Up to 60 numbers that were recently sent or received via your phone will be stored in a Recent Call Log (in the order they were dialled/received). You can select a number to dial from the log.

1. Press the **[Send]** button while in standby mode.

The Recent Call Log is displayed.

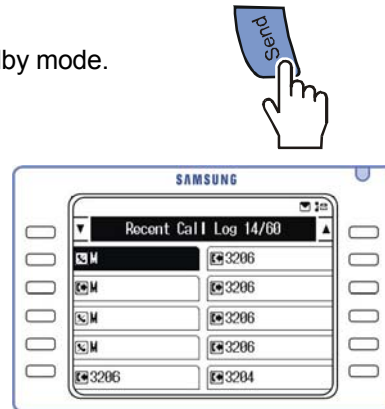

2. Use the direction buttons to move the cursor to the desired telephone number.

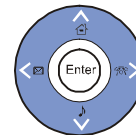

3. Press the **[Send]** button to dial the call, or the **[Enter]** button to view information about the number selected.

- If you press the [Send] button, the call is connected to the selected number automatically through the speakerphone. You can switch from the speakerphone to the handset by lifting the handset.
- If you press the [Enter] button, you see information including the called party's name, time their call was made or received, and call duration. After viewing this information, press the [Send] button to dial the number.



Speed Dialling

Frequently dialled telephone numbers can be programmed in a system-wide list of speed dial numbers (500–999 or 050–999*) or your personal speed dial list of numbers (00–49). Telephone numbers can then be automatically dialled for you at the press of a button.

1. With the phone in standby mode and the handset down, press the **[Screen]** button repeatedly until the Fixed Feature Menu screen appears.

- Or, press **[1][6]**, the function code for speed dialling.



2. Press the **[Selection]** button for **[SPEED DIAL]** displayed on the Fixed Feature Menu screen.

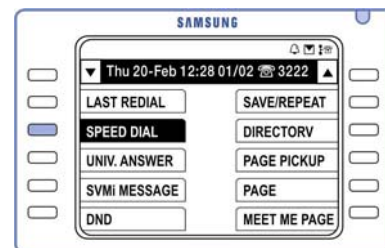

3. Press the speed dial number required.
The called phone will ring.

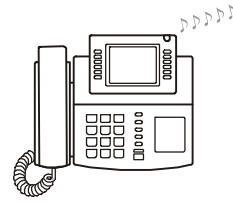

4. Begin speaking when the called party answers.

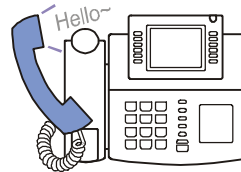

* Your system can have up to either 500 or 950 system speed dials, depending on how the system is set up. All phone users can access the system speed dial numbers 500 (or 050) to 999.

The personal list of numbers (00 to 49) are numbers that can be used only on your station. The system administrator determines the maximum number of personal speed dial numbers allowed.

To register new speed dial numbers, or search the list, refer to the **Navigation Menus (Phone Book)** part of the guide

Dialling from Directory Names

Extension and speed dial numbers, with associated names, can be stored in your phone's directory. You can select numbers using the directory name list, which is in alphabetical order.

1. With the phone in standby mode, press the **[Screen]** button repeatedly until the Fixed Feature Menu screen appears.



2. Press the **[Selection]** button for the **[DIRECTORY]** menu on the Fixed Feature Menu screen.

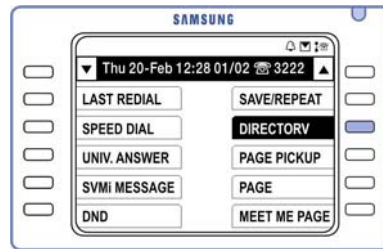

3. Press the **[Selection]** button for the directory menu to be searched: **[PERSONAL DIR]**, **[SYSTEM DIR]** or **[STATION DIR]**.
 - These are your personal numbers, system numbers or station (extension) numbers



4. Enter the first letter of the desired name (using the dial buttons)* and press the **[▼Volume▲]** buttons to search for the name.

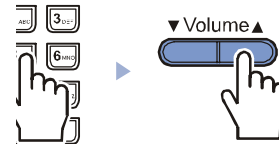

5. When name appears, press the **[Selection]** button for **[DIAL]** to dial the number.

Begin speaking when the called party answers.

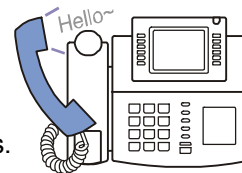

*To enter characters, refer to 'Entering Characters' in **Things You Should Know**.

It is possible to move directly to the directory you require without having to select it. Ask your system administrator for details.

HANDLING CALLS

1. Intercom Calls

The following features can be used during an intercom call. The Hold feature is useful for temporarily disconnecting a call to which you want to return. To hold a call and answer a waiting call, refer to *Answering a Waiting Call* in **Answering Calls**.

Hold an Intercom Call

You can put a call on hold and resume the call later.

1. Press the **[Hold]** button and replace the handset to put the current call on hold.
 - If using the speakerphone, press **[Hold]** and then the **[Speaker]** button to put on hold.
 - When the call is on hold, the held party hears music or a voice message depending on the system setting.

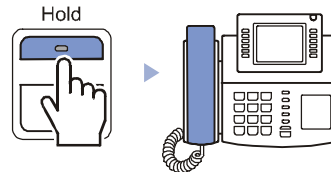

2. Lift the handset and press the **[Hold]** button to resume the call.

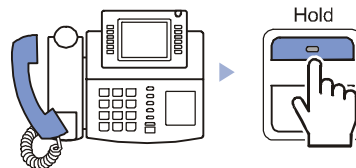

Mute Your Phone

To temporarily prevent your voice being heard while on a call, use the Mute feature.

1. Press the **[Selection]** button for the **[MUTE(ON)]** feature displayed on the screen. You cannot be heard by the other party.



2. Press the **[Selection]** button for the **[MUTE(OFF)]** feature to clear the Mute function. You can again be heard by the other party.

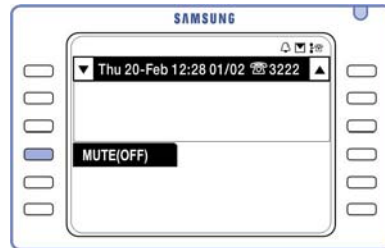

2. External Calls

The following features can be used during an external call. The Hold feature is useful for temporarily disconnecting a call to which you want to return later. To hold a call and answer a waiting call, refer to 'Answering a Waiting Call' in **Answering Calls**.

Hold an External Call

You can put a call on hold and resume the call later.

1. Press the **[Hold]** button to put the call on hold
 - Pressing the [Hold] button *once* puts the call on 'system hold' so you can reconnect to the call from any phone.
 - Pressing the [Hold] button *twice* puts the call on 'exclusive hold' so you can reconnect to the call only from your own phone.



2. Press the **[Screen]** button until the AOM screen is displayed.



The call number on hold flashes on the screen.

3. To resume the call, press the **[DT]** button for the flashing number on hold.

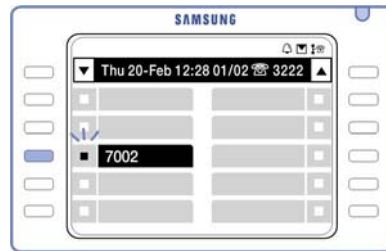

4. Resume your conversation.

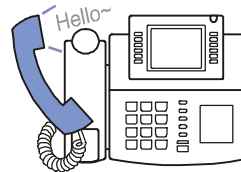

Hold an External Call and Make an Intercom Call

You can put an external call on hold and make a call to another station. This is useful, for example, if you need to consult with a colleague during your call.

1. Press the **[Transfer]** button.

The external caller will hear Transfer Call tone.



2. Dial the station number.



3. Begin speaking when the called party answers.

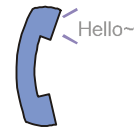

4. Press the **[Transfer]** button to reconnect to the external call on hold.





You can toggle between the external and intercom calls by pressing the [Transfer] button.

Call Transfer

If an external caller requests to speak with someone else, you can transfer the call to the requested station or external number.

1. Press the **[Transfer]** button during the call.



2. Press the station or external number (recipient) to which the call should be transferred.



3. Disconnect the call (e.g. replace the handset)
 - To transfer the call automatically, disconnect the call when the recipient's phone rings. Otherwise, wait until the recipient answers your call, inform them of the transfer, then disconnect the call.

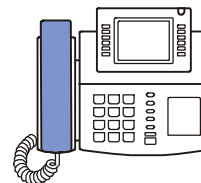



If the recipient of the transferred call does not answer or rejects an automatic transfer, the call returns (or *recalls*) to your phone. Answer the call as normal.

If you wait for confirmation of the transfer and the recipient does not answer or rejects the transfer, you can press the [Transfer] button to re-connect to the external call.

If the recipient is busy, you can disconnect and park the call, then notify the busy station of the parked call (see **Call Parking**, below.)

Call Parking

You can place a call in a 'parking orbit' and announce the call over a paging system for someone to pick up. There is a total of 10 (0–9) selectable parking orbits.

■ Parking a Call

1. During a call, press the **[Screen]** button until the AOM screen is displayed.



2. Press the **[Selection]** button for the **[PARK]** menu on the AOM screen.



3. Press the **orbit number (0–9)** to park the call.

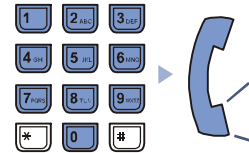

Make a page to announce on which orbit the call is parked and for whom it is intended. (See 'Paging' in **Convenience Features**.)



See also 'Call Park and Page' in **Convenience Features**.

■ Answering a Parked Call

When a parked call is announced, press the **[Selection]** button for the **[PARK]** menu on the AOM screen and dial the orbit number. You will be connected to the call.

Transfer Calls to the Voice Mailbox

You can transfer an incoming call to your voice mailbox, if this exists. (The phone system should have a Voice Mail card installed and the system administrator should have enabled the voice mailbox function.)

1. When a call arrives, press the **[Screen]** button and then press the **[Selection]** button for the **[VT]** feature on the AOM screen.

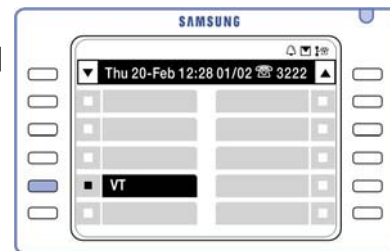

2. Dial the voice mailbox number.



3. Use the voice mailbox features when the voice mailbox is connected.

- Refer to your Voice Mail guide for details.



Voice Mailbox



You can record a personal greeting in your mailbox with helpful messages. Callers can also leave messages for you in the mailbox.

3. Intercom and External Calls

The following functions are available for use during both intercom and external calls.

Conference Calls

Up to five parties, including yourself as the conference supervisor, can participate in a conference call simultaneously. If your system has been programmed with conference groups, you can select a group to conference—see **Load Group for Conference**, below. Alternatively, you can enter each number to conference on the LCD screen as described here.

1. Press the **[Conference]** button in standby mode.



2. Press the left **[Selection]** button for a number entry field and enter a phone number to conference, then press the **[Enter]** button.

Enter all numbers to conference (up to four) in the same way.



Confirm each number by pressing the **right [Selection]** button for the entry field. Press the button again if you want to cancel an entry.

3. Press the **[Selection]** button for **[Send All]**.

The conference connection status of all the numbers is displayed.



- To delete a number from the conference, press the **[Selection]** button for **[Delete]** to the right of the number.



You can also dial the conference function code [4][6] to set up a conference. (The procedure is as described in the user guide for 2-line LCD phones.)

Load Group for Conference

1. Press the **[Conference]** button in standby mode.



2. Press the **[Selection]** button for the **[Group]** menu to display the group(s).
 - You can load or delete a number in the group by moving to the group and pressing the **[Menu]** button. Select the **[Save]** menu and save the entered number to the group.

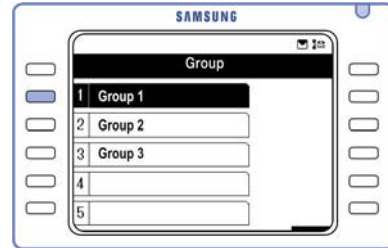

3. Use the direction buttons to move to the required group and press the **[Enter]** button. The numbers listed in the group are shown.



4. Press the **[Selection]** button for **[Send All]**.



Your system must be programmed with conference groups and your phone set to Enbloc dialling mode for you to use this feature.

CONVENIENCE FEATURES

1. Call Forwarding

If you are unable to answer incoming calls for any reason, they may be transferred to another station. You can select the condition under which calls should be forwarded: for example, forward all calls when you are away from your desk or when you are busy on a call.

Call forwarding is set using the appropriate function codes. (Lift the handset to dial the codes if the Hot Keypad feature is not set on your phone.)

- Call Forwarding can also be set using the Navigation Menus. Refer to the 'Call Forwarding' section in **Navigation Menus**.

Forward All Calls

You can set a call forward to another station for **all** incoming calls (unconditional).

1. Press **[6][0][1]** in standby mode and dial the number to which all calls should be forwarded.



2. Wait for the tone confirmation tone.

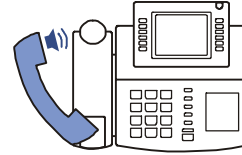

Forward Busy

You can set a call forward to another station for calls that arrive when you are busy on another call.

1. Press **[6][0][2]** in standby mode and dial the number to which calls should be forwarded.



2. Wait for the confirmation tone.

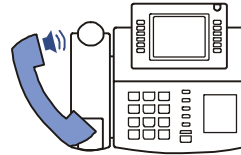

Forward No Answer

You can set a call forward to another station for calls that you do not answer within a specified time.

1. Press **[6][0][3]** in standby mode and dial the number to which calls should be forwarded.

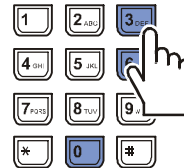

2. Wait for the confirmation tone.

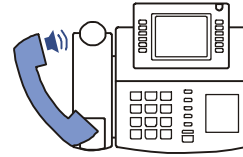

Forward Busy/No Answer

You can set a call forward to another station for calls which either arrive while you are busy on another call or you do not answer within a specified time. This option can only be set if forward destinations are already separately set for both Busy and No Answer conditions (above).

1. Press **[6][0][4]** in standby mode.



2. Wait for the confirmation tone.



Forward Follow Me

If you intend to temporarily relocate to a different position, you can forward calls that are incoming to your usual phone to the phone at the new position (that is, you cause your calls to follow your movements). The function code to do this is entered *at the phone in the new location*.

This feature can also be used for remote call forwarding: that is, to transfer to your phone calls that are incoming to another station (remote call forwarding).

1. Press **[6][0][6]** in standby mode at the station to where calls are to be forwarded.

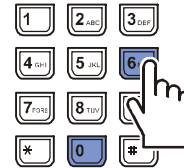

2. Enter the number of the station from where calls are to be forwarded.



3. Wait for the confirmation tone.



Forward DND

DND is Do Not Disturb mode. You can set this mode (described below) if you don't want calls to ring at your phone. However, you can instead choose to automatically forward any calls when DND mode is set.

1. Press **[6][0][5]** in standby mode and dial the number to which calls should be forwarded.



2. Wait for the confirmation tone.

When you next go into DND mode, calls will be forwarded to the programmed destination.



Cancel Call Forwarding

You can cancel any call forwarding set at your phone.

Lift the handset and press **[6][0][0]**

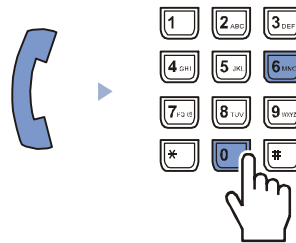

2. Do Not Disturb (DND)

If you set DND mode on your phone, incoming calls are forwarded to the DND forward destination (if programmed—see **Forward DND**, above) or callers will receive busy tone.

Setting / Cancelling DND

1. Press the **[Screen]** button until the Fixed Feature Menu screen is displayed.

- Or, press the DND setup code, **[4][0][1]**.



2. Press the **[Selection]** button for **[DND]** displayed on the screen.

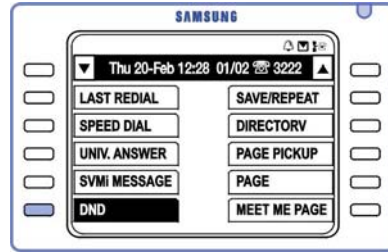

3. Press the **[Selection]** button for **[ON]** to set DND.
 - Or, to cancel a DND setting, press the **[Selection]** button for **[OFF]**. The status indicator stops flashing.

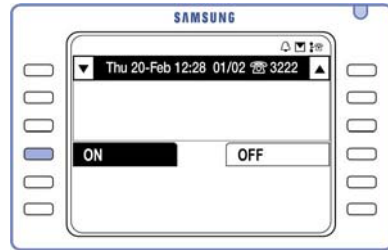

4. The status indicator blinks to notify that the DND mode is set. You will hear confirmation tone.

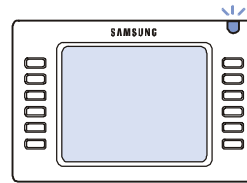

3. Paging

The system allows you to make page announcements internally to individual stations or groups of stations via their speakerphones, or externally via speakers in work areas such as offices or factories. An additional All Page feature allows you to do both.

Stations and speakers are arranged in zones which you can select. When making a page announcement, you should use the handset for best audio quality.

Internal Page

To page announce through station speakers.

1. Lift the handset
 - Or, press the Page function code [5][5].



2. Press the **[Selection]** button for the **[PAGE]** menu displayed on the screen.

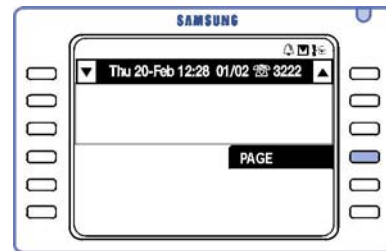

3. Select the internal page zone by pressing [1], [2], [3], or [4]. Press [0] to page all internal zones.

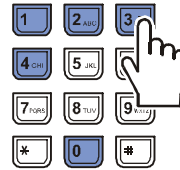

4. Deliver the announcement after the confirmation tone. The announcement will be broadcast to stations in the selected zone.



5. Replace the handset after completing the page.

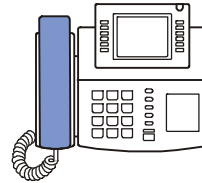

External Page

To page through external speakers.

1. Lift the handset.
 - Or, press the Page function code [5][5].



2. Press the **[Selection]** button for the **[PAGE]** menu displayed on the screen.

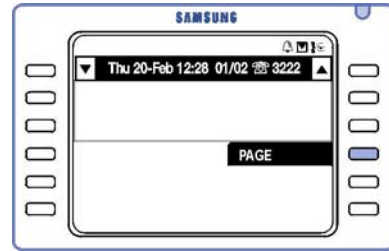

3. Select the external zone by pressing **[5]**, **[6]**, **[7]**, or **[8]**. Press **[9]** to page all external zones.

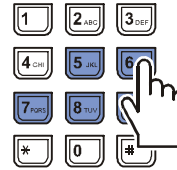

4. Deliver the announcement after the confirmation tone. The announcement will be broadcast through speakers in the external zone.

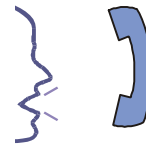

5. Replace the handset after completing the page.

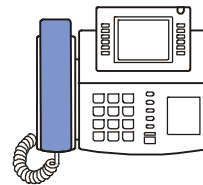

All Page

To page announce through both station and external speakers.

1. Lift the handset

- Or, press the Page function code [5][5].



2. Press the **[Selection]** button for the the **[PAGE]** menu displayed on the screen.

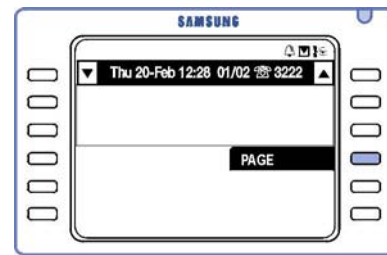

3. Press the **[*]** button.

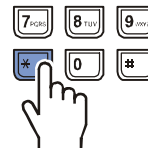

4. Deliver the announcement after the confirmation tone. The announcement will be broadcast through speakers in the external and internal zones.

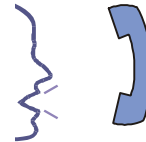

5. Replace the handset after completing the page.

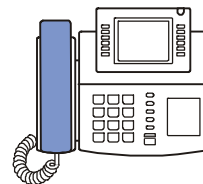

Meet Me Page

You can make a page to an individual and have them dial a code to connect to your phone.

1. Lift the handset.
 - Or, press the Meet Me Page function code [5][4].



2. Press the **[Selection]** button for the the **[MEET ME PAGE]** menu displayed on the screen.



3. Press the page zone number (0–9).



4. Instruct the recipient to press **[5][6]** after the confirmation tone.



5. The “**Press the [ANSWER WAIT]...**” message is displayed on the screen.

Press the **[Selection]** button for **[ANSWER WAIT]**.

- Or, press [Transfer] then [5][4].

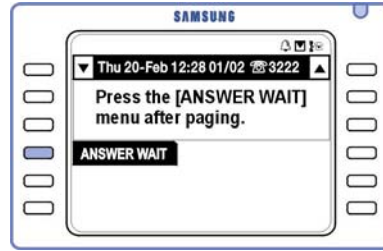

6. The “**Wait until the recipient responds**” message is displayed. Hold on to the handset until the recipient answers.



7. When the recipient answers, their line is automatically connected to yours.

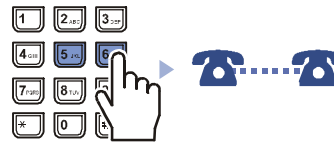

Call Park and Page

If you have an external call at your phone that you wish to transfer to another station but the station user is away from their desk, you can park the call and page the individual to pick up the parked call from another extension. Intercom calls cannot be parked or paged.

1. Press the **[Selection]** button for the **[PAGE]** menu while the call is on line.
The call is automatically parked.



2. Press the number of the page zone where the recipient is normally located, or press the **[*]** button to page **all** internal and external zones



3. Wait for the confirmation tone and announce the call and the station number or trunk line number where the call is parked.



4. Disconnect the call.
 - If the parked call is not answered within a specified time, the call recalls to your phone

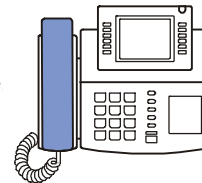

Page Pickup

Allows you to connect to the extension or trunk line number advised in a Call Park and Page announcement (above).

1. Lift the handset and press the **[Screen]** button until the Fixed Feature Menu screen is displayed.

- Or, press the Page Pickup function code [1][0].



2. Press the **[Selection]** button for the **[PAGE PICKUP]** menu displayed on the screen.

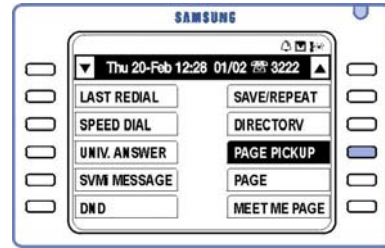

3. Press the phone number announced in the page.

The line is connected to the parked call.



4. Off-Hook Voice Announce (OHVA)

You can make announcements to a busy station through the station's speakerphone or handset. This feature is useful when you have an urgent message to deliver.

You can also receive OHVA from other stations. You can put your current call on hold and answer the OHVA. However, you also have the option to reject or block OHVA calls.

Make OHVA

Both the handset and speakerphone may be used for OHVA, but the handset is recommended since making announcements to nearby stations through the speakerphone may cause echoes.

1. Dial the station number and press the **[Selection]** button for **[OHVA]**.

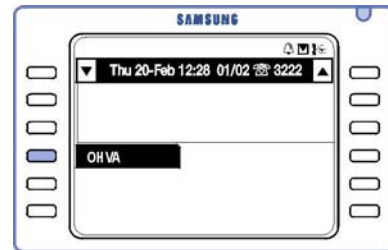

2. After the warning tone, deliver your announcement.

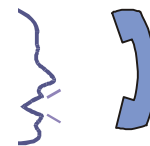

3. Disconnect the call by replacing the handset or by pressing the **[Speaker]** button or **[End]** button.

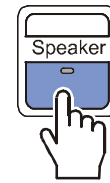

OHVA will not work with phones that have the DND option enabled.
OHVA will work with intercom calls and transferred calls.

Answer OHVA

When an OHVA call is connected, the selection box for the station number flashes on the AOM screen. Press the **[Screen]** button and the flashing **Call** button to put the current call on hold and connect to the OHVA caller.



An OHVA must be answered within a programmable time (usually 10 seconds) or it will be automatically cancelled.

Cancel OHVA

After the OHVA call is finished, press the **[Send]** button to resume your original call.



Reject OHVA

You can reject an OHVA before it is finished.

While listening to OHVA, press the **[Selection]** button for **[REJECT]** to disconnect the OHVA call and resume your original call.

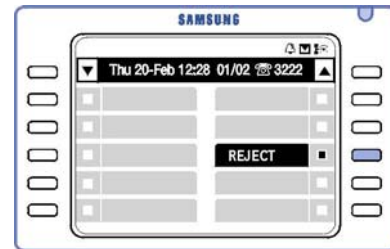

Block OHVA

You can set the OHVA Block feature which prevents other users from making an OHVA call to you when you are on a call.

1. Press the **[Screen]** button until the Fixed Feature Menu screen is displayed.



2. Press the **[Selection]** button for **[OHVA BLOCK]** displayed on the screen.
 - Or, press the [Selection] button for [OFF] to cancel an OHVA Block.

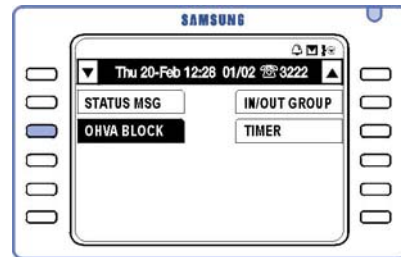

5. Messaging

Messaging is done in two ways: you can leave a Message Waiting Indication at another phone for the user to call you back when they are not busy; or you can display a message at your phone so others are aware of your situation when you are absent from your desk.

Leaving a Message Waiting Indication

When calling a station that does not answer or is busy, you can leave a message waiting indication to notify the user to call you back. The indication takes the form of a flashing status indicator or button LED, or a special dialling tone, depending on the type of phone receiving the indication. Similarly, indications can be left at your station by others.

(This feature does not apply to external calls.)

1. Press the **[Screen]** button until the AOM screen is displayed.
 - Or, press the message function code [4][3].
2. Press the **[Selection]** button for **[MESSAGE]**.



3. Wait for the confirmation tone and disconnect the call.

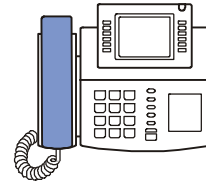

■ Cancelling Message Waiting Indications

It is possible to cancel any message waiting indication you have left at another station, as well as any left at your station by others.

Dial **[4][2]** and enter the station number.

- Enter your own number to delete all messages at your station, or refer to **Verify, Return or Delete Message**, below, to selectively delete indications left at your station.



Verify, Return or Delete an Indication

The keyset status indicator flashes red when a message indication is left at your phone. You can check the number of each calling station and either ring them back or delete the indication(s), as required.

1. Press the **[Screen]** button until the AOM screen is displayed.
 - Or, press the message function code **[4][3]**.



2. Press the **[Selection]** button for the **[MESSAGE]** menu.



3. The number of the first station that has left a message indication is displayed along with the menus **[REPLY]**, **[NEXT]**, and **[CLEAR]**.

- Press the **[Selection]** button for the **[REPLY]** menu to reply to the message. The number of the station

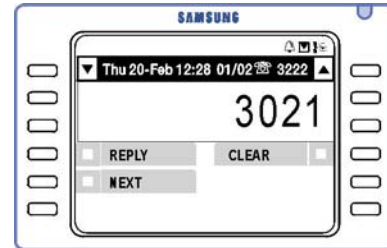

is automatically dialled. If the station does not answer, the status indicator continues to flash and you can try again later, or delete the indication.

- If more than one indication is left at the phone, press the **[Selection]** button for **[NEXT]** to move to the next message, and reply or delete.
- Press the **[Selection]** button for **[CLEAR]** to delete the indication.

Programmed Messages

If you are intending to be away from your desk for a while, you can select or create a message to inform others of your situation. The message displays on your phone's LCD and will also display on a calling station's LCD.

A total of 20 messages are available to you. Messages 01–15 are set by the system administrator as standard messages. By default, the first 10 of these (01–10) are preset as shown below but may be changed. Check with your system administrator what messages are set.

01 GIVE ME THE CALL
02 TAKE A MESSAGE
03 ASK THEM TO HOLD
04 SEND TO MY VM
05 TRSF TO MY SECY
06 LEAVE A MESSAGE
07 PAGE ME
08 OUT OF TOWN
09 IN A MESSAGE
10 I WILL CALL BACK

1. Lift the handset and press the **[Screen]** button until the Fixed Feature Menu screen is displayed.
 - Or, press the Programmed Messages function code [4][8].



2. Press the **[Selection]** button for the **[STATUS MSG]** menu.

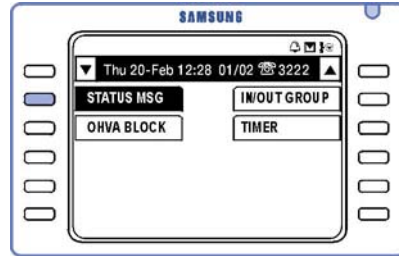

3. Enter the Programmed Message code.
 - To cancel a set message, press the **[Selection]** button for the **[STATUS MSG]** menu and press the cancel code [0][0].



The message displays on your phone.



Programmed Messages can also be set using the Navigation Menu. You can also set your own personal messages. See ‘Setting Absence Messages’ in **Navigation Menu (Configuration)**.

6. Executive/Secretary Hot Line

To use the Executive/Secretary Hot Line feature your phone must be set as a *secretary* or *executive* phone. An icon, indicating an executive or secretary, is displayed in the upper part of the LCD screen. (See your system administrator if you're not sure.) This allows a secretary to set the status of the executive to be displayed on the phone, to set up messages for sending between the secretary and executive, and to intercept calls for the executive and transfer them if appropriate.

Executive Status Display

To set an appropriate display to indicate the status of the executive:

1. In standby mode, press the **[Screen]** button until the Executive Status screen is displayed.
2. Press the **[Selection]** button corresponding to the status of the executive.

Screen

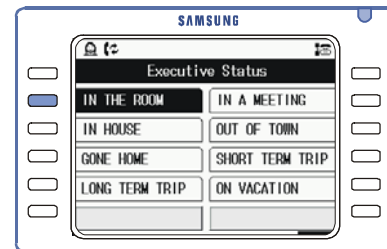

Call Transfer from Secretary to Executive

When the executive line is busy or has Do Not Disturb set, the secretary can receive calls for the executive and transfer them, if appropriate.

1. Answer and verify the nature of the call. Then, press the **[Selection]** button for **[BOSS/SECR]** and notify the executive of the call.

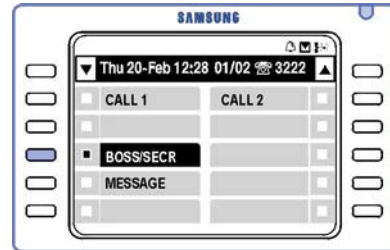

2. Replace the handset to transfer the call to the executive.
 - If the executive does not answer or rejects the call, reconnect with the caller by pressing the [Hold] button.

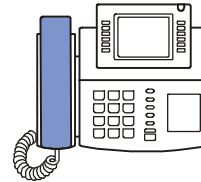

Executive/Secretary Messages

You can create messages that are commonly exchanged between the executive and secretary phones so they are available to quickly select when required. There are no preset messages in the system.

Create and Send Messages

1. In standby mode, press the **[Screen]** button until the Fixed Feature Menu screen is displayed.



2. Press the **[Selection]** button for the **[EXE/SECR MSG]** menu.

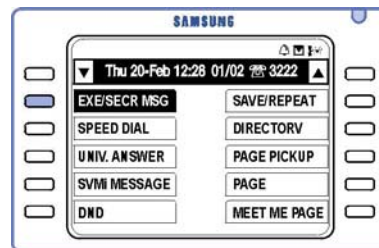

3. Press the **[Selection]** button for the extension number of the recipient.
 - This screen is not displayed if there is only one executive or secretary phone.
 - Up to four recipients may be selected.

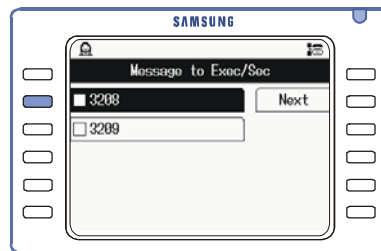

4. Press the **[Selection]** button for the message you want to send.

If there are no messages set up, you see blank messages only.
Create your message as follows:



- (i) Move to the 'Blank Message' field where you want to enter a new message and press the **[Menu]** button.

- (ii) Move to the **[Edit]** menu and press the **[Enter]** button.

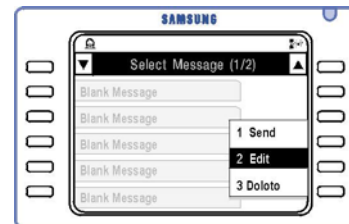

- (iii) Enter the message in the Input Message screen. The message can be up to eight characters long.

Then, press the **[Enter]** button.

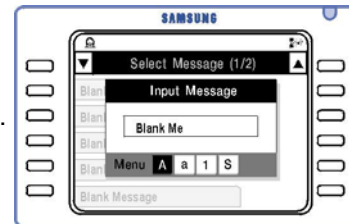

7. In/Out of Group

If your phone is assigned to a station group, you can remove it from the group if required. If the phone is removed from the group, you can answer calls to your extension number but you cannot answer calls to the group. You can reassign the phone to the group at any time.

1. In standby mode, press the **[Screen]** button until the Fixed Feature Menu screen is displayed.



2. Press the **[Selection]** button for the **[IN/OUT GROUP]** menu.

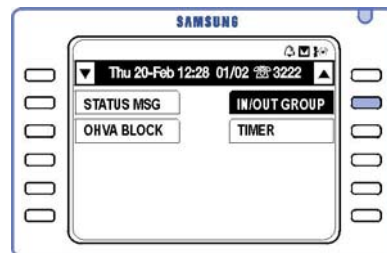

3. To remove your phone from the group, press the **[Selection]** button for **[OUT OF GROUP]**.

To reassign your phone to the group, press the **[Selection]** button for **[IN GROUP]**.



8. Group Listening

You can allow others to hear your conversation through the speaker while on a call. The microphone is disabled while this feature is active.

1. During the call, press the **[Selection]** button for **[GROUP LISTEN]**.

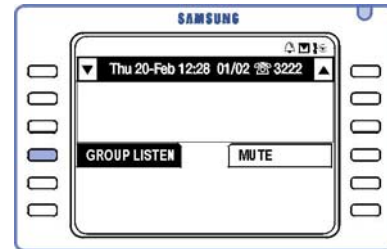

Others can now hear the conversation through the speaker, but cannot be heard by the calling/called party

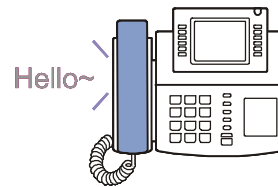

2. To disable the speaker and resume a private conversation, press the **[Selection]** button for **[LISTEN(OFF)]**.

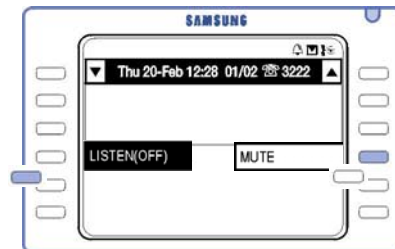

If you want to disconnect the call after group listening, always select **[LISTEN(OFF)]** before disconnecting to prevent any squeals from the phone.

9. Caller ID (CID) Presentation

Your system can be programmed to display a caller's number and name (the caller's ID, or CID) when you receive a call. This service is provided by your telephone company. However, CID will not be provided in the following situations:

- If the caller requests no display of the phone number.
- If the call is from areas where the CID Presentation service is not provided (e.g. international calls).
- If the call is from a public phone.
- If the information sent is corrupted.
- If the telephone company fails to transmit the CID.

To set the type of CID Presentation you want on your phone, refer to 'Setting the Type of Caller ID (CID) Display' in **Navigation Menu (Configuration)**.

There are a number of useful options that take advantage of CID displays.

Saving Caller Number

When the CID is displayed, press the **[Selection]** button for **[SAVE]** displayed on the screen.

The caller's number is saved in the phone's memory and can be selected for dialling. It will be kept in the memory until you save another number.



Dialling a Saved Caller Number

Press **[1][7]** to dial the saved number.



Storing a Caller Number as a Speed Dial Number

1. When the CID is displayed, press the **[Selection]** button for **[STORE]** displayed on the screen.



2. The speed dial number in which the caller number is saved is displayed on the screen.

To dial using speed dial numbers, see 'Speed Dialling' in **Making Calls**.

Viewing the CID of Calls Parked or On Hold

You can verify the CID for a call that is parked or on hold before answering the call.

1. When the phone is in standby mode, or during a call, press the **[Selection]** button for the **[INQUIRE]** menu displayed on the screen.

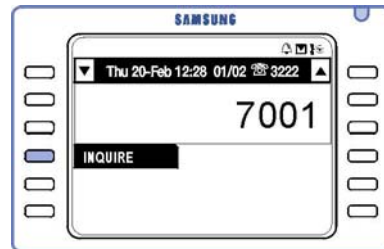

2. Press the trunk line number displayed on the screen to verify the CID.

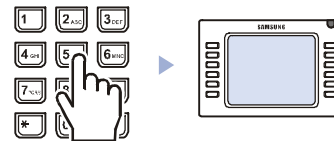

The CID of the trunk line number is displayed on the screen.

3. When the inquiry is finished, press the **[Send]** button to answer the call, OR press the **[Selection]** button for the **[NND]** menu to view more information about the call, OR press the **[Selection]** button for **[IGNORE]** to return to standby mode.





If you are on a station call, the call should be disconnected or put on hold before verifying the CID of a trunk line call.

10. Call Duration Display

If the Call Duration Display function is enabled, the duration of calls through the trunk line is displayed on the LCD screen.

- **Incoming trunk calls:** The duration is displayed the moment you answer a call.
- **Outgoing trunk calls:** The duration is displayed after a preset time or when the recipient answers the call.

11. Door Phone Related Features

If the door phone and your phone are connected, you can answer or call the door phone from your station.

Answering the Door Phone

1. When a call arrives at the door phone, your phone rings three consecutive short bursts.

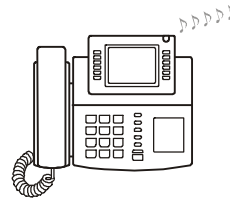

2. Lift the handset or press the **[Speaker]** button or **[Send]** button to connect to the door phone.



3. If an electric door lock is installed, press **[1][3]** to open the door.

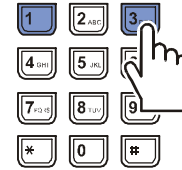

Calling the Door Phone

You can call the door phone to listen to what is happening in another room.

Dial the number of the door phone.
You can listen or speak through the door phone.

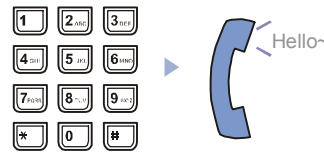

12. Background Music

If background music is set on the system, you can listen to it through your phone's speaker.

1. Press the **[Hold]** button to listen to background music.

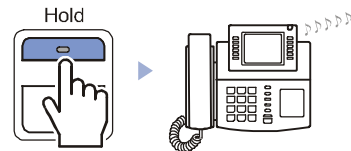

2. You can adjust the volume using the **[▼Volume▲]** buttons (this will not affect the default speaker volume setting).

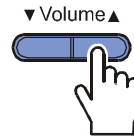

3. Press the **[Hold]** button again to turn off the music.

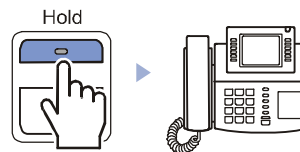

Only the system administrator can set and change the background music.

NAVIGATION MENUS

1. Navigation Buttons

The Navigation buttons look like this:

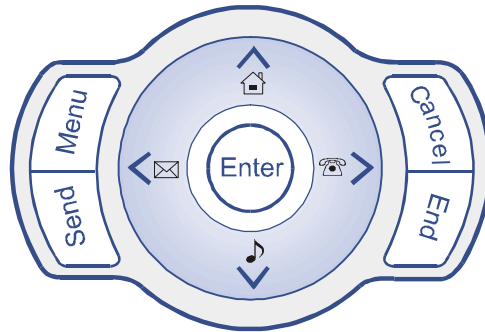

Menu Button

When the **[Menu]** button is pressed in standby mode, main menus are displayed as icons.



If the **[End]** button or **[Speaker]** button is pressed while in menu mode, the phone automatically exits menu mode.

Send Button

The [Send] button is used to:

- Send a call after you have dialed a phone number.
(Your phone is set to 'Enbloc' mode by default. However, if this is changed you do not need to press [Send].)
- Verify the most recently called/received number.
- Answer forwarded calls.
- Dial the most recently called number

Enter Button

The [Enter] button is used in menu mode to select or save the corresponding item.

Direction Buttons

Direction buttons are used to move between items or to edit item contents.

① [^] button is used

- When moving the cursor upward in menu mode.
- When moving to a higher-level item of the current menu.

② [>] button is used

- When moving the cursor to the right in menu mode.

③ [v] button is used

- When moving the cursor downward in menu mode.
- When moving to a lower-level item of the current menu.

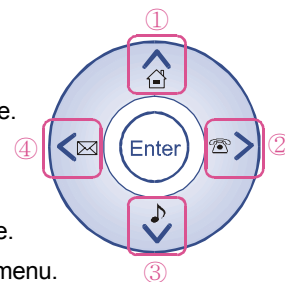

④ [<] button is used

- When moving the cursor to the left in menu mode.

Cancel Button

- Moves to the previous stage of menu mode.
- Deletes the entered letter or number.
- Cancels menu mode.

End Button

- Disconnects the call.
- Exits from menu mode.

2. Entering Menus

When the phone is in standby mode, press the **[Menu]** button on the Navigation buttons. The Phone Menu appears on the LCD screen.

Selecting Menus

Use the direction buttons to move to the desired menu (icon). Then, press the **[Enter]** button.

Alternatively, press the dial button corresponding to the number of a menu, 1–7 (e.g. P-Book is 1 and My-Phone is 7).

Press the **[End]** button to exit menu mode.

 NOTE

If the station is connected to an external call in menu mode, the phone becomes busy. If there is a black bar at the bottom right of the LCD panel, you can press the [Menu] button to perform other functions.

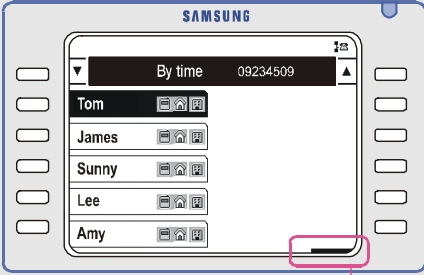

[Menu] button

3. Phone Book

Press the **[Menu]** button and use the direction buttons to select



Then, press the **[Enter]** button.

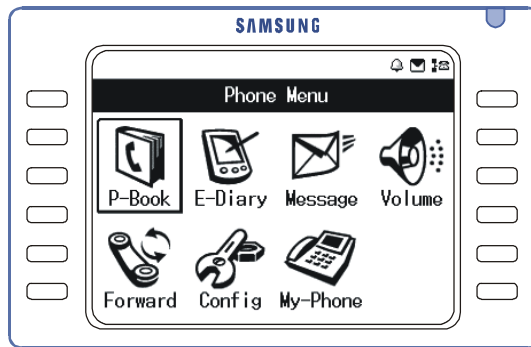

Move to the desired menu and press the **[Enter]** button.

Search by Speed Dial Number Location

You can search for a telephone number based on the speed dial numbers registered with the phone.

1. Press the **[Menu]** button and use the direction buttons to select



→ **[1. Search]** → **[1. By Speed Dial No]**

Then, press the **[Enter]** button.

2. When the speed dial number entry screen appears, enter the speed dial number and press the **[Enter]** button.

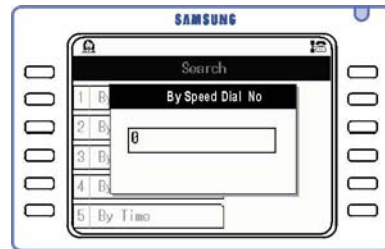

3. The telephone number corresponding to the entered number is displayed.
 - If you press the **[Enter]** button without entering the speed dial number, a list of all phone numbers will be displayed.
4. Press the **[Send]** button to dial the selected telephone number.
 - To change or delete the speed dial number, press the **[Menu]** button. When the popup menu appears, select the desired menu (Edit / Delete / New Entry).

Search by Name

You can search for a telephone number based on the names registered with the phone.

1. Press the **[Menu]** button and use the direction buttons to select



→ **[1. Search]** → **[2. By Name]**

Then, press the **[Enter]** button.

2. You are prompted to enter a name.
Enter the name or part of a name to search for and press the **[Enter]** button.

(Refer to *Entering Characters* in **Things You Should Know** for how to enter characters.)

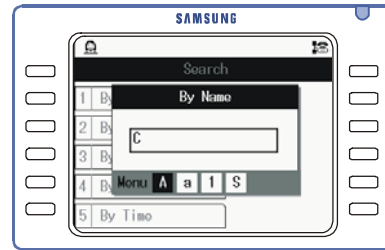

The speed dial name(s) matching the entry will be displayed.

- If you press the **[Enter]** button without entering a speed dial number, a list of all the telephone numbers will be displayed.

3. Press the **[Enter]** button to view the saved details for the selected number.
 - To change or delete the speed dial name, press the **[Menu]** button. When the popup menu appears, select the desired menu (Edit / Delete / New Entry).
4. Move to the desired telephone number and press the **[Send]** button to dial the number.

Search by Number

You can search for a number based on the number itself or part of the number registered in the phone.

1. Press the **[Menu]** button and use the direction buttons to select



→ **[1. Search]** → **[3. By Phone Number]**

Then, press the **[Enter]** button.

2. You are prompted to enter a telephone number.
Enter the number or part of the number to search for and press the **[Enter]** button.



The entered telephone number is displayed.

- If you press the **[Enter]** button without entering a phone number, a list of all telephone numbers will be displayed.
- If you enter only part of the telephone number, a list of all telephone numbers that contain the entered digits will be displayed.
 - Entering *123* searches for all numbers that contain the sequence 123.
 - Entering 123* searches for all numbers that start with 123.
 - Entering *123 searches all numbers that end with 123.

3. Press the **[Enter]** button to view details of the telephone number.
 - To change or delete the speed dial number, press the **[Menu]** button. When the popup menu appears, select the desired menu (Edit / Delete / New Entry).

4. Move to the number you want to call and press the **[Send]** button.

Search by Group

You can search for telephone numbers using personalised groups previously registered in the phone. Refer to **Registering New Numbers** and **Editing Groups** later in this section.

1. Press the **[Menu]** button and use the direction buttons to select



→ **[1. Search]** → **[4. By Group]**

Then, press the **[Enter]** button.

2. Move to the desired group from the list of registered groups and press the **[Enter]** button.

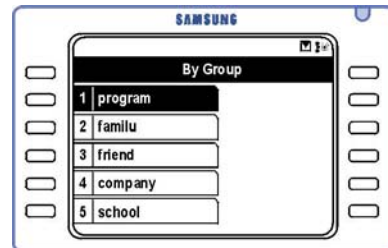

3. Select a phone number (mobile phone, home, work, etc) and press the **[Enter]** button.
4. Move to the telephone number you want to call and press the **[Send]** button.
 - To change or delete the selected number, press the **[Menu]** button. When the popup menu appears, select the desired menu to change, delete or register the number.

Search by Time

You can search for any telephone number based on the time the number was registered in the phone. Speed dial names will be displayed commencing with the latest entry.

1. Press the **[Menu]** button and use the direction buttons to select



→ **[1. Search]** → **[5. By time]**

Then, press the **[Enter]** button.

2. When the list of registered numbers is displayed, select the number and press the **[Enter]** button.

- To change or delete the number, press the **[Menu]** button. When the popup menu appears, select the desired menu **Edit/Delete/ New Entry**.

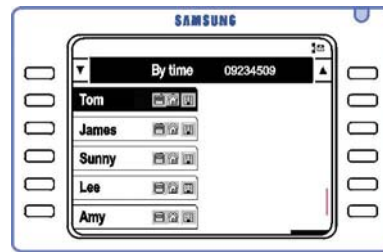

3. Move to the telephone number you want to call and press the **[Send]** button.

Recently Called Numbers

The last 30 numbers you called are saved in memory. You can review these numbers and redial any of them automatically.

1. Press the **[Menu]** button and use the direction buttons to select



→ **[2. Outgoing Calls]**

Then, press the **[Enter]** button.

2. Move to the desired telephone number and press the **[Enter]** button.

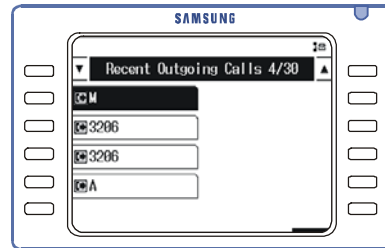

3. Press the **[Send]** button to dial the selected telephone number.
 - To delete the selected number, press the **[Menu]** button. When the popup menu appears, select the menu to delete the number (or delete **all** saved calls).

Recent Caller Numbers

Call details and caller ID, if available, of the last 30 incoming calls are saved in the incoming call log. You can review these numbers and dial them automatically.

1. Press the **[Menu]** button and use the direction buttons to select



→ **[3. Incoming Calls]**

Then, press the **[Enter]** button.

2. Move to the desired telephone number and press the **[Enter]** button.

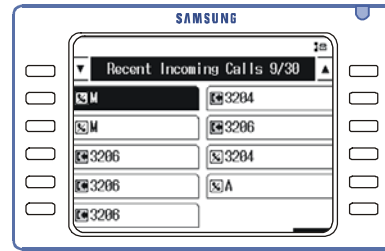

3. Press the **[Send]** button to dial the selected number.
 - To delete the selected number, press the **[Menu]** button. When the popup menu appears, select the menu to delete the number (or delete **all** saved calls).

Registering New Numbers

You can save 1000 speed dial names and 2,400 telephone numbers in your Phone Book. Each speed dial name can have the following information registered: up to five telephone numbers (home, mobile phone, office, etc), fax, e-mail, group, and notes. Each speed dial number can also be allocated a speed dial number location.

1. Press the **[Menu]** button and use the direction buttons to select



→ **[4. New number]**

Then, press the **[Enter]** button.

2. Use the direction buttons to move to each item and enter the relevant information.

(Refer to *Entering Characters* in the **Things You Should Know** section of this guide for how to enter characters.)

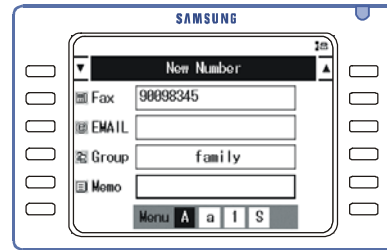

3. Press the **[Enter]** button. The 'Saved' message appears, confirming the information is saved.

Editing Groups

This procedure allows you to establish personalised groups to which speed dial names can be assigned. This means you can search for speed dial numbers by group.

1. Press the **[Menu]** button and use the direction buttons to select



→ **[5. Edit Group]**

Then, press the **[Enter]** button.

2. A list of registered groups appears (if they exist).

3. Press the **[Menu]** button to add, edit or delete a group.
(Group1 provides the option to 'Add' only.)

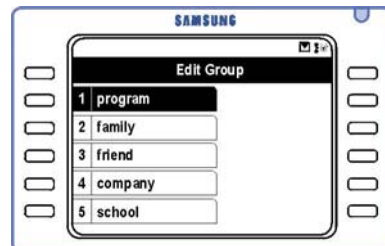

To add a group:

Press the [Menu] button and select the [Add] menu. Enter the group name to register and press the [Enter] button.

To edit a group name:

Select the group to Edit and press the [Menu] button. Then, select the [Edit] menu.
Enter the group name and press the [Enter] button.

To delete a group:

Select the group to delete from the list and press the [Menu] button. Then, select the [delete] menu. When the 'Do you want to delete?' message appears, select [Yes] and press the [Enter] button.

Deleting All Telephone Numbers

To delete all saved telephone numbers:

1. Press the **[Menu]** button and use the direction buttons to select



→ **[6. Delete all]**

Then, press the **[Enter]** button.

2. When the Password entry screen appears, enter the password set in the phone.
 - By default, the password is 1234. If it has been changed and you cannot remember it, see your system administrator.

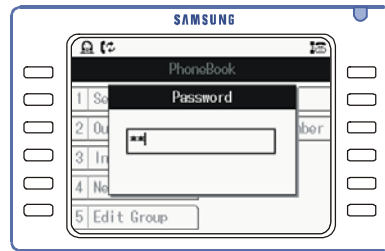

3. When the 'Are you sure you want to permanently delete your data?' message appears, select **[Yes]** and press the **[Enter]** button.

All the telephone numbers saved in the Phone Book will be deleted.

- Recent caller/called numbers are not deleted.

Checking Your Own Extension Number

You can check your own extension number if you need to.

Press the **[Menu]** button and use the direction buttons to select



Then, press the **[Enter]** button.

Your number is displayed.



4. E-Diary

Press the **[Menu]** button and use the direction button to select



Then, press the **[Enter]** button.

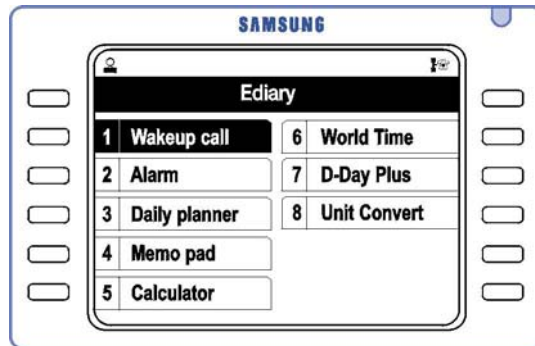

Move to the desired menu and press the **[Enter]** button.

Wakeup Call

Allows you to set a wakeup call to ring for three minutes or until answered. The frequency options for a wakeup call are: every day, Monday–Friday, or Monday–Saturday.

1. Press the **[Menu]** button and use the direction buttons to select



→ **[1. Wakeup Call]**

Then, press the **[Enter]** button.

2. Set the Time, Ring, and Repeat items.

- **Time**=time of alarm
- **Ring**=1-5 or Silent
- **Repeat**=frequency (e.g. every day)

Change the **[Clear]** item to **[Save]** by pressing the Navigation button [**<**] or [**>**]. Then press the **[Enter]** button to save the setting.

- If you select **[Clear]** and press the **[Enter]** button, the set wakeup call will be cleared.



Alarm Clock

This is similar to the Wakeup Call function except that the frequency of the alarm is limited to once only, or every day. Two separate alarm times are available.

1. Press the **[Menu]** button and use the direction buttons to select



→ **[2. Alarm]**

Then, press the **[Enter]** button.

2. Select **[Alarm clock 1]** or **[Alarm clock 2]**.

3. Set the Time, Ring, and Repeat items for the selected alarm clock.

- **Time**=time of alarm
- **Ring**=1-5 or Silent
- **Repeat**=frequency (e.g. every day)

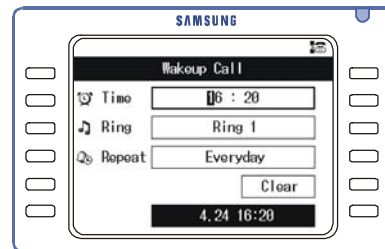

Change the [Clear] item to [Save] by pressing the Navigation button [<] or [>].

Then press the **[Enter]** button to save the setting.

- If you select [Clear] and press the [Enter] button, the set wakeup call will be cleared.

Daily Planner

The Daily Planner allows you to schedule events and have the system notify you when an event is to commence. Up to 30 event schedules can be registered.

- A note up to 32 characters long can be associated with each scheduled event. If the note is more than eight characters long, it can be viewed by selecting it, pressing the [Menu] button and then OK. An available ring tone can be selected.
- An alarm can be set to ring at the set time (the “exact” time), an hour before the set time, or 30 minutes before.

■ Schedule Registration

1. Press the **[Menu]** button and use the direction buttons to select



→ **[3. Daily Planner]**

Then, press the **[Enter]** button.

2. Use the direction buttons to select the date to be registered and press the **[Menu]** button.
Select 'Add' (press the **[Selection]** button).

3. Use the direction buttons to move to the schedule items. Set the Date, Time, Contents, Alarm, and Ring items and press the **[Enter]** button.

- **Time**=time of alarm
- **Ring**=1-5 or Silent
- **Alarm**=at the set time (the exact time)
/1 hour before set time/30 mins before set time



■ Checking/Adding/Modifying/Deleting the Schedule

1. Press the **[Menu]** button and use the direction buttons to select



→ **[3. Daily Planner]**.

Then, press the **[Enter]** button.

2. Use the direction buttons to select the date of the set schedule. Press the **[Enter]** button.

3. Press the **[Menu]** button and then:
 - Select **[Add]** to add a new schedule.
 - Select **[Edit]** to modify the schedule.
 - Select **[Delete]** to delete the schedule. (When the 'Do you want to delete?' message appears, select **[Yes]** and press the **[Enter]** button.)

- Select **[Delete All]** to delete all set schedules. (When the 'Do you want to delete?' message appears, select **[Yes]** and press the **[Enter]** button.)



Memo Pad

Allows you to save a simple memo.

■ Entering a Memo

1. Press the **[Menu]** button and use the direction buttons to select



→ **[4. Memo Pad]** → **[1.Add New Memo]**

Then, press the **[Enter]** button.

2. Enter the memo in the Memo screen and press the **[Enter]** button.

(Refer to *Entering Characters* in the **Things You Should Know** part of this guide for how to enter characters.)

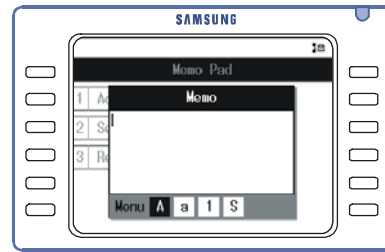

■ Checking/Modifying/Deleting/Registering Memos

1. Press the **[Menu]** button and use the direction button to select



→ **[4. Memo Pad]** → **[2.Search]**

Then, press the **[Enter]** button.

2. Select the desired memo and press the **[Menu]** button, then:
 - Press **[Add]** to add a new memo.
 - Press **[Edit]** to modify a memo.
 - Press **[Delete]** to delete the memo.
 - Press **[Delete All]** to delete all memos.

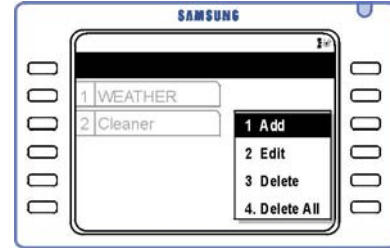

3. Press the **[Enter]** button.

Calculator

A simple calculator is available to add, subtract, multiply, and divide numbers.

1. Press the **[Menu]** button and use the direction buttons to select

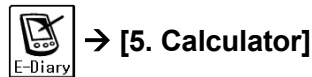

Then, press the **[Enter]** button.

2. Enter the first number. Then, press the direction buttons to select a calculation operator (\div , \times , $-$, $+$).
 - Press the **[#]** button to enter a negative number, the **[*]** button to enter a decimal point, or the **[Cancel]** button to delete incorrectly entered numbers.

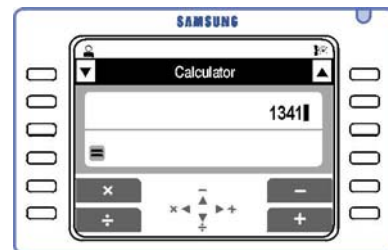

3. Enter the second number.
 - If there are more numbers to enter, select another operator, then a number, then another operator, etc, until all numbers are entered.
4. Press the **[Enter]** button to perform the calculation.

World Time

Allows you to search for the local time in 39 cities and regions around the world (Guam, New York, Dallas, Tokyo, Denver, La Paz, London, Rome, Miami, Moscow, Midway, Bangkok, Berlin, Buenos Aires, Beijing, Samoa, San Francisco, Seoul, Sydney, Chicago, Abu Dhabi, Athens, Alaska, Alma Tai, Oakland, Okhotsk, Wellington, Los Angeles, Jakarta, Middle Atlantic, Tashkent, Phoenix, Caracas, Cape Verde, Paris, Hawaii, Honolulu, Helsinki, and Hong Kong).

1. Press the **[Menu]** button and use the direction buttons to select



→ **[6. World Time]**

Then, press the **[Enter]** button.

2. Use the direction buttons to select the city where you want to check the local time. (The line moves and displays the city, date and time.)

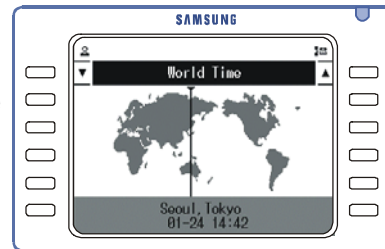

■ Changing the Time Zone

To change the time zone displayed on the phone:

- Press the **[Menu]** button while in the World Time display. The message 'Do you want to change time zone?' is displayed.
- Select **[Yes]** and press the **[Enter]** button.
- Select the time zone (e.g.: Sydney) and press the **[Enter]** button.

D-DAY Plus

D-DAY Plus allows you to enter an important schedule so that you can check the time remaining until, or the time passed since, the entered date (D-Day). The D-DAY can be entered directly, or can also be entered automatically by calculating the number of days before/after the entered base date.

■ Entering a New D-DAY

1. Press the **[Menu]** button and use the direction button to select



→ [7. D-Day Plus] → [1. D-Day Add]

Then, press the **[Enter]** button.

2. Select [1. D-Day Exact Date] and set each option to enter a D-Day directly. Then, press the **[Enter]** button.

- Select [2. D-Day Base/Off] and set the base date, number of days, and before/after D-Day menus to calculate and enter a D-Day.

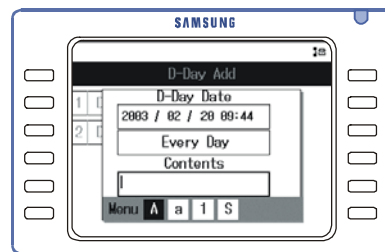

■ Searching a List of D-Days

1. Press the **[Menu]** button and use the direction buttons to select



→ **[7. D-Day Plus]** → **[2. D-Day Search]**.

Then, press the **[Enter]** button.

2. When the list of registered D-Days appears, press the direction buttons to select the desired D-Day item.

- Select the desired D-Day from the D-Day Search screen and press the **[Enter]** button to check the details.



3. Press the **[Menu]** button to edit or delete the settings for the selected D-Day.

Unit Conversion

This feature provides a simple conversion program for commonly used units of measurement for temperature, length, weight, volume, and area.

1. Press the **[Menu]** button and use the direction buttons to select



→ **[8. Unit Convert]**

Then, press the **[Enter]** button.

2. Use the direction buttons to select the category (Length, Weight, Area, Volume, Temp). Then, press the **[Enter]** button.

3. Specify each item: unit to convert (e.g. centimeter), unit value, and unit of conversion (e.g. metre) and press the **[Enter]** button.

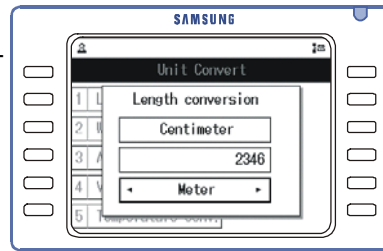

The converted value is displayed.

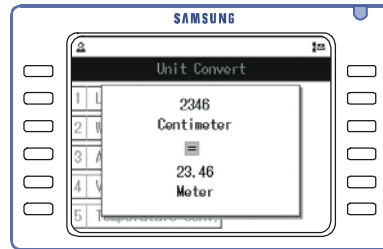

5. Messages

Press the **[Menu]** button and use the direction buttons to select



Then, press the **[Enter]** button.

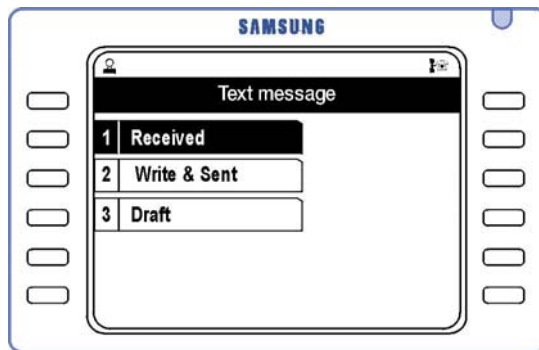

Move to the desired menu and press the **[Enter]** button.

Received Messages

Allows you to check text messages or set the status of message reception.

1. Press the **[Menu]** button and use the direction buttons to select



Then, press the **[Enter]** button.

2. When new messages are received, the display shows the number of messages.

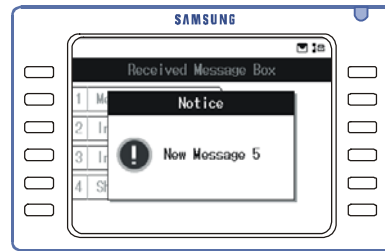

■ Message Charge

You can review received text messages and decide how you wish to be notified of the arrival of a new text message.

1. Press the **[Menu]** button and use the direction buttons to select



Then, press the **[Enter]** button.

2. Select a message from the list of messages and press the **[Enter]** button to view the message.
 - If the message is too long for the screen, use the direction buttons to scroll through.

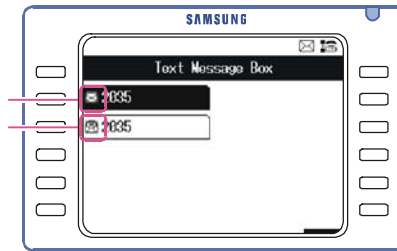

3. Press the **[Menu]** button to reply to, resend, or delete the message (or delete all messages).

■ Setting a Message Arrival Alarm

Allows you to set an alarm (1-5) notifying you of message arrival.

1. Press the **[Menu]** button and use the direction button to select



→ [1. Received] → [2. TextMsg.Setup] → [2. Indi. Tone]

Then, press the **[Enter]** button.

2. Select an alarm and press the **[Enter]** button.
 - Alarms are 1/2/3/4/5: The alarm you specify rings according to the interval setting (see below).

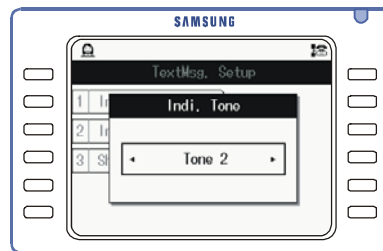

■ Setting Message Arrival Notice Interval

You can set how the message alarm notifies you of a new message arrival.

1. Press the **[Menu]** button and use the direction buttons to select



→ [1. Received] → [2. TextMsg.Setup] → [1. Indi. Interval]

Then, press the **[Enter]** button.

2. Select the notification interval.

- **Once:** Alarm rings once when a message arrives.
- **Every 2 Minutes:** Alarm rings every 2 minutes until you view the message.
- **No Tone:** You are not notified when a message arrives.

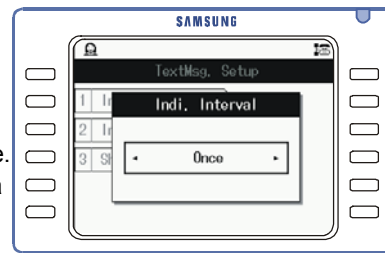

Then, press the **[Enter]** button.

■ Setting/Clearing Message Display

Allows you to select whether to display the contents of the message when a message arrives.

1. Press the **[Menu]** button and use the direction buttons to select



→ [1. Received] → [2. TextMsg.Setup] →
[3. Show Contents]

Then, press the **[Enter]** button.

2. Select whether to display the contents of the message when a message arrives.
 - Select [Save] to display a popup screen with the contents of the received message.
 - Select [Clear] to display a popup screen without displaying the contents of the received message.

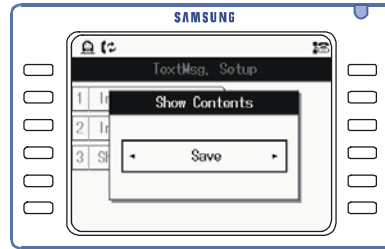

Then, press the **[Enter]** button.

Sent Messages

Allows you to write and send a new message. In addition, messages saved in the Sent message box and the Reserved message box can be resent through the Sent message box function.

1. Press the **[Menu]** button and use the direction buttons to select



Then, press the **[Enter]** button.

2. Select the desired menu and press the **[Enter]** button.

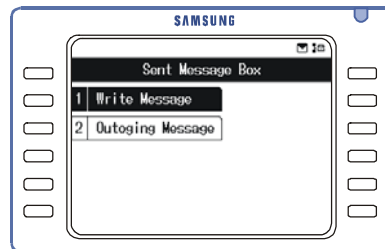

■ Writing a Message

To write and send a text message:

1. Press the **[Menu]** button and use the direction buttons to select



→ **[2. Write & Sent]** → **[1. Write Message]** →
[1. Write New Message]

Then, press the **[Enter]** button.

2. Enter the phone number to receive the message (in **Recipient**) and the message (in **Contents**). Press the **[Enter]** button to send message.

(Refer to *Entering Characters in Things*

You Should Know for how to enter characters.)

- If sending succeeds, the screen prompting you to save the message in the sent message box will be displayed. Select **[Yes]** and press the **[Enter]** button to save the message.
- If sending fails, the screen prompting you to save the message in the reserved message box will be displayed. Select **[Yes]** and press the **[Enter]** button to save the message.



■ Retrieving and Sending a Message

You can retrieve saved messages in the Text Message box and send them (after modification, if required).

1. Press the **[Menu]** button and use the direction buttons to select



→ **[2. Write & Sent]** → **[1. Write Message]** →
[2. Invoke Message]

Then, press the **[Enter]** button.

2. Use the direction buttons to move to the message to be retrieved and press the **[Enter]** button.



You can add new text, or edit text, and send the message using the displayed options.

- You can also delete the message, or delete all saved messages.

■ Managing the Sent Message Box

You can check, delete or resend sent or reserved messages saved in the Sent Message box. These messages cannot be modified.

1. Press the **[Menu]** button and use the direction buttons to select



→ **[2. Write & Sent]** → **[2. Outgoing Message]**

Then, press the **[Enter]** button.

2. Select the number of the sent message.

- Press the **[Menu]** button to select the message.
- To view the message, press the **[Enter]** button.

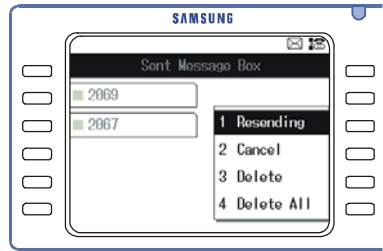

The selected message can be resent to another person or deleted.

- Select **[Delete All]** to delete **all** the messages from the Sent Message Box.

Draft

Draft messages are messages you have written and saved but not sent (e.g. messages that were interrupted during writing, due to, for example, an arriving call). These messages can be retrieved and completed.

■ New Message Registration

1. Press the **[Menu]** button and use the direction buttons to select



→ **[3. Draft]** → **[1. New Message]**.

Then, press the **[Enter]** button.

2. Enter the new message and press the **[Enter]** button.

(Refer to *Entering Characters* in the **Things You Should Know** part of this guide for how to enter characters.)



■ Searching Messages

Allows you to search for messages saved as drafts.

1. Press the **[Menu]** button and use the direction buttons to select



→ **[3. Draft]** → **[2. Search Message]**.

Then, press the **[Enter]** button.

2. Use the direction buttons to move to the message to be retrieved and press the **[Menu]** button.

- To view the message, select the message and press the **[Enter]** button.
- You can select to send, modify, or delete the message (or to delete all draft messages).
- When free space in the Draft is 20% of the total space, the screen on the right appears. Delete unwanted messages from the Draft.



6. Volume Adjustment

Press the **[Menu]** button and use the direction buttons to select



Then, press the **[Enter]** button.

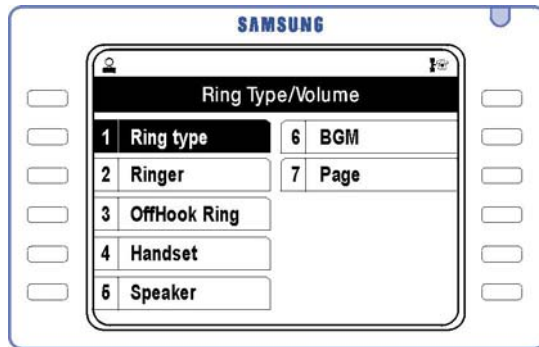

Move to the desired menu and press the **[Enter]** button.

Selecting a Ring Type

There are eight ring types. To select the ring type:

1. Press the **[Menu]** button and use the direction buttons to select



→ **[1. Ring type]**

Then, press the **[Enter]** button.

- Use the [**<**] and [**>**] direction buttons to select the desired ring type.

The phone rings to demonstrate each ring as it is selected.

Then, press the [**Enter**] button.

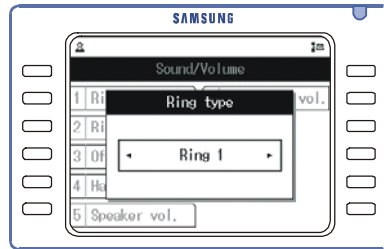

Ringer Volume

There are eight volume levels. To set the ringer volume:

- Press the [**Menu**] button and use the direction buttons to select

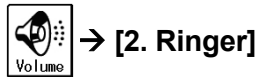

Then, press the [**Enter**] button.

- Press the [**▼ Volume ▲**] buttons to select the volume level, and press the [**Enter**] button.

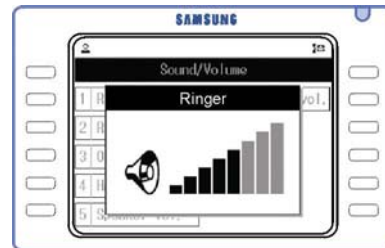

Off-Hook Volume

There are eight volume levels for the Off-Hook ringer. To set the level:

1. Press the **[Menu]** button and use the direction buttons to select



Then, press the **[Enter]** button.

2. Press the **[▼Volume▲]** buttons to set the volume level, and press the **[Enter]** button.

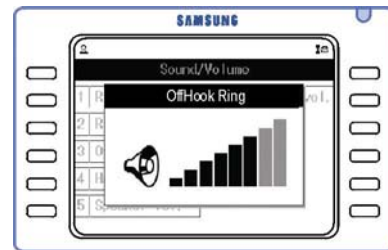

Handset Volume

There are eight volume levels you can set for the handset.

1. Press the **[Menu]** button and use the direction buttons to select

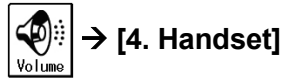

Then, press the **[Enter]** button.

2. Press the **[▼Volume▲]** buttons to set the volume level, and press the **[Enter]** button.

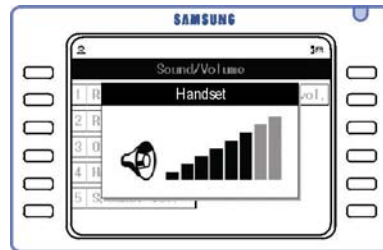

Speaker Volume

There are 16 volume levels you can set for the speaker.

1. Press the **[Menu]** button and use the direction buttons to select

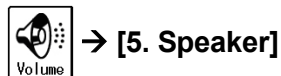

Then, press the **[Enter]** button.

2. Press the [**▼Volume▲**] buttons to set the volume level, and press the [**Enter**] button.



Background Music (BGM) Volume

There are 16 volume levels you can set for BGM volume when BGM is set on your phone.

1. Press the [**Menu**] button and use the direction buttons to select

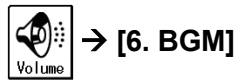

Then, press the [**Enter**] button.

2. Press the [**▼Volume▲**] buttons to set the volume, and press the [**Enter**] button.

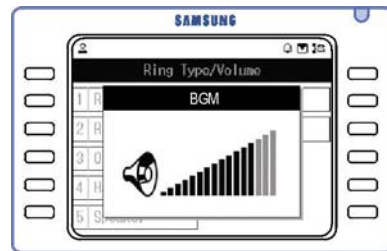

Page Volume

There are 16 levels of page volume you can set.

1. Press the **[Menu]** button and use the direction buttons to select

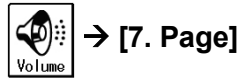

Then, press the **[Enter]** button.

2. Press the **[▼Volume▲]** buttons to set the volume, and press the **[Enter]** button.

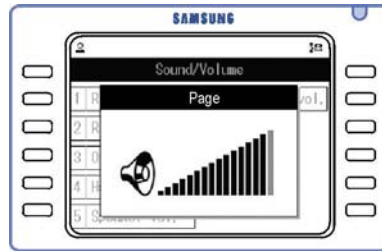

7. Call Forwarding

You can set your phone to forward incoming calls to another specified extension. A number of forward options are available for you to select (refer to 'Call Forwarding' in **Convenience Features** for more details).

1. Press the **[Menu]** button and use the direction buttons to select



Then, press the **[Enter]** button.

2. Use the direction buttons to move to the desired forward option, and press the **[Menu]** button.

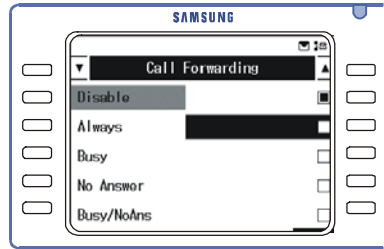

3. If the phone number to forward is saved, select [Save] and press the **[Enter]** button.

4. If the phone number is not saved or you want to modify the saved phone number, select [Edit] and press the **[Enter]** button. Enter the phone number and press the **[Enter]** button and repeat step 3.

8. Configuration

Press the **[Menu]** button and use the direction buttons to select



Then, press the **[Enter]** button.

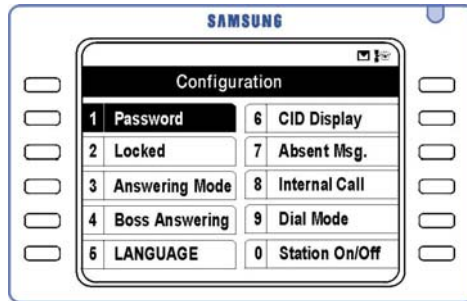

Move to the desired menu and press the **[Enter]** button.

Changing Your Password

This option allows you to change the 4-digit password which is used to prevent unauthorised use of your phone or to set certain phone features.

- Default value of password is 1234.

1. Press the **[Menu]** button and use the direction buttons to select

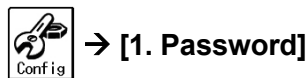

Then, press the **[Enter]** button.

2. Enter the four digits of the current password and press the **[Enter]** button.

- The entered password is displayed as asterisks (*).

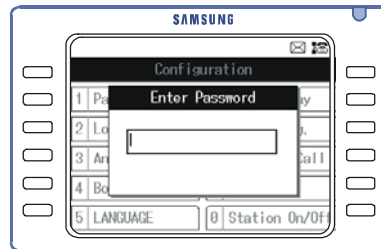

3. The **[New Password]** screen appears. Enter a new password and press the **[Enter]** button.

4. The **[Confirm New Password]** screen appears. Re-enter the new password to confirm and press the **[Enter]** button.

Locking Your Phone

If you lock your phone, this prevents others from using it without your permission. There are three options:

- **Unlocked:** Phone is not locked (this is the default setting).
- **Locked All:** Prevents phone from making or receiving any calls.

- **Locked Out:** Prevents phone from making outside calls.

1. Press the **[Menu]** button and use the direction buttons to select

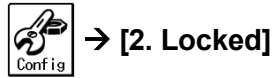

Then, press the **[Enter]** button.

2. Enter the password for the phone.
- Default value of password is **1234**.
 - If you cannot remember your password, see your system administrator.

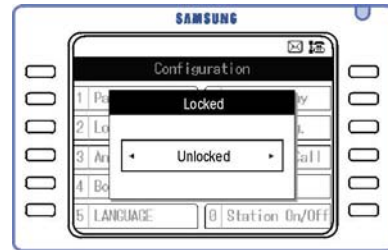

3. Use the direction buttons to select the lock option.

Then, press the **[Enter]** button.

Setting the Answer Mode

The answer mode can be set to Ring, Auto Answer or Voice Announce. Ring mode is the normal setting where you have to lift the handset or press the **[Send]** button to answer. Auto Answer and Voice Announce modes automatically answer calls for you.

1. Press the **[Menu]** button and use the direction buttons to select



Then, press the **[Enter]** button.

2. Use the direction buttons to select the answering mode.

- **Ring:** The phone rings when a call arrives.
- **Auto Answer Mode:** The phone automatically answers an incoming call.
- **Voice Announce:** You hear the caller's voice through the speaker and you must lift the handset or press the [Send] button, to be connected to the caller.

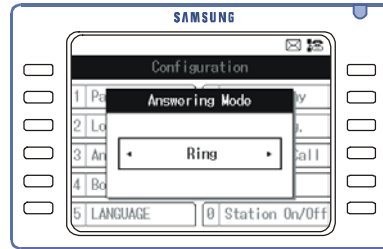

Then, press the [Enter] button.

Setting the Boss Answering Mode

To set the boss answering mode the phone must be assigned as a “boss” station in programming. The options for answering are the same as those described in **Setting the Answer Mode**, above.

1. Press the [Menu] button and use the direction buttons to select



→ [4. Boss Answering]

Then, press the [Enter] button.

2. Use the direction buttons to select the boss answering mode.

- **Ring:** The phone rings when a call arrives.
- **Auto Answer Mode:** The phone automatically answers an incoming call.

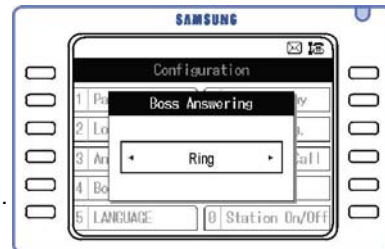

- **Voice Announce:** You hear the caller's voice through the speaker. Lift the handset or press the [Send] button, to be connected to the caller.

Then, press the **[Enter]** button.

Phone Language

You can set the language for the LCD screen display (e.g. English).

1. Press the **[Menu]** button and use the direction buttons to select



Then, press the **[Enter]** button.

2. Press the direction buttons to select the language.

- The language is set to English by default.

Then, press the **[Enter]** button.

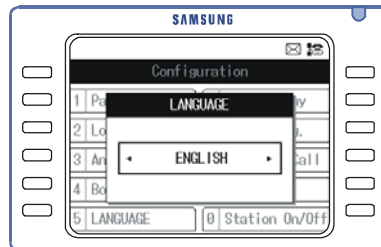

Setting the Type of Caller ID (CID) Display

The CID display on the LCD can be the caller's name or number (or you can select 'no display'). To select the display you want:

1. Press the **[Menu]** button and use the direction buttons to select.



→ **[6. CID Display]**

Then, press the **[Enter]** button.

2. Use the direction buttons to select the type of caller ID display.

- **None:** Caller IDs are not displayed.
- **Name :** If the name of a caller is registered with the [Phone Book], the name will be displayed. If not, the caller's telephone number will be displayed.
- **Number :** The telephone number of the caller is displayed.

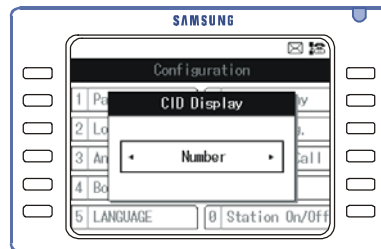

Then, press the **[Enter]** button.

Setting Absence Messages

If you are likely to be away from your station for a while, you can set a message to be displayed on the LCD. The message also displays on any calling phone's LCD.

Up to 15 standard messages (numbered 01–15) may be registered with the system for you to select. Your system administrator can tell you what they are. To enter a personal message, you can select one of the messages numbered 16 to 20 which are blank by default.

1. Press the **[Menu]** button and use the direction buttons to select



Then, press the **[Enter]** button.

2. Use the direction buttons to select the desired absence message and press the **[Enter]** button.

- To clear an absence message, move to the message, press the **[Menu]** button and select **[Clear]**.
- To enter a personal message, move to one of the messages 16 to 20, press the **[Menu]** button, and select the **[Modify]** menu to see the message input screen. Enter a message of up to eight characters. (For information on how to enter characters, refer to *Entering Characters* in **Things You Should Know**.)

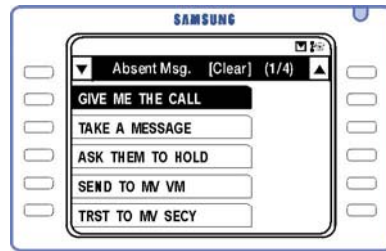

Displaying Internal Calls

You can select to display either numbers or names of internal extensions on the AOM screen.

1. Press the **[Menu]** button and use the direction buttons to select



Then, press the **[Enter]** button.

- Use the direction buttons to select Number or Name.

Then, press the **[Enter]** button.

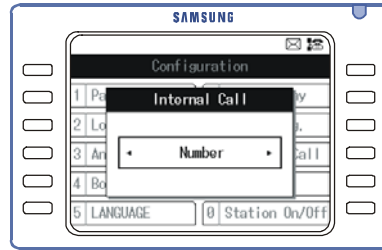

Dial Mode

Your phone is set to 'Enbloc' dialling mode by default. This means you must press the [Send] button after entering a phone number in order to make a call. In the alternative 'Overlap' mode, the call is made immediately you finish entering the number. You can select the mode you prefer.

The advantage of Enbloc dialling is the ability to correct a wrongly entered number before it is dialled.

- Press the **[Menu]** button and use the direction buttons to select



→ **[9. Dial Mode]**

Then, press the **[Enter]** button.

- Use the direction buttons to select the dial mode.

Then, press the **[Enter]** button.

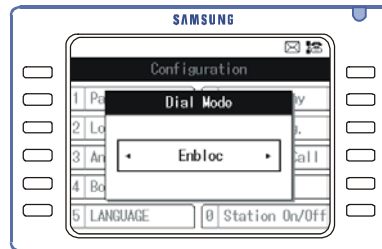

Switching Station Features On and Off

The phone has a number of features which can be turned on or off as required. Your system administrator can provide you with more information on these features and how they are used. They include:

AUTO HOLD	AUTO CAMPON
AUTO TIMER	DISPLAY SPD NAME
HEADSET USE	SECURE OHVA
HOT KEYPAD	CALL COST DISP
PAGE REJOIN	CID REVIEW ALL
RING PREF	STOP CID DISPLAY
AME P/W	AUTO ANS CO CALL

1. Press the **[Menu]** button and use the direction buttons to select



→ **[0. Station ON/OFF]**

Then, press the **[Enter]** button.

2. Move to the desired feature and press the **[Enter]** button to select On or Off.

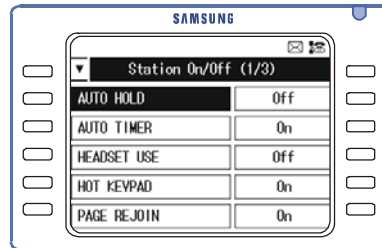

9. My Phone

The My-Phone icon allows you to select a number of other options for your phone.

Press the **[Menu]** button and use the direction buttons to select



Then, press the **[Enter]** button.

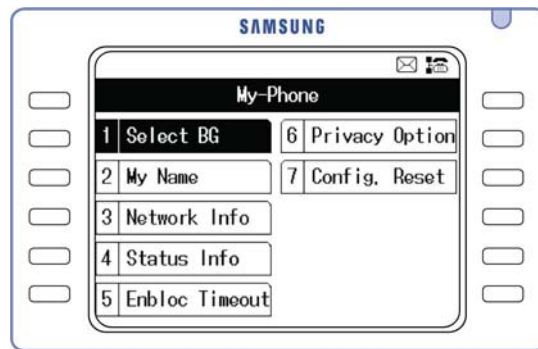

Move to the desired menu and press the **[Enter]** button.

Selecting the Background Screen

This option allows you to set the start-up background screen on the LCD. The selections are calendar / spring / summer / autumn / winter images.

1. Press the **[Menu]** button and use the direction buttons to select

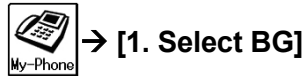

Then, press the **[Enter]** button.

2. Use the **Scroll** key or the direction buttons to select the desired screen and press the **[Enter]** button.

Default calendar screen

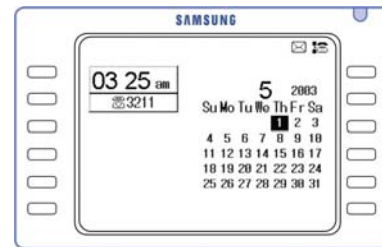

Entering Your Name

Your name is displayed on the LCD screens of internal phones to which you make a call. You enter your name as follows.

1. Press the **[Menu]** button and use the direction buttons to select

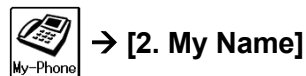

Then, press the **[Enter]** button.

2. When the name input screen appears, enter a name of up to five characters and press the **[Enter]** button.
 - Refer to *Entering Characters* in **Things You Should Know** for how to enter characters.

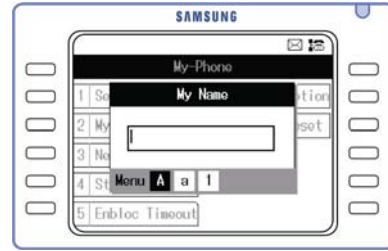

Network Information

You can view the network information for your phone.

Press the **[Menu]** button and use the direction buttons to select



→ **[3. Network Info]**

Then, press the **[Enter]** button.

The network information is displayed.

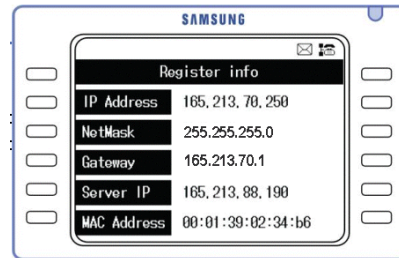

Viewing Status Information

The status of the following features you have set on the phone can be displayed: Call Forwarding, Absent Message, DND, and Lock.

Press the **[Menu]** button and use the direction buttons to select



Then, press the **[Enter]** button.

The status information is displayed.



Enbloc Timeout

Allows you to select a valid time for the interval between entering a phone number and pressing the [Send] button when the dial mode of the phone is set to 'Enbloc'. Valid times are 30 seconds, 1 minute or 3 minutes. When you subsequently enter a number to make a call, you must press [Send] before this time expires, otherwise the number is cancelled and you will need to re-enter it.

1. Press the **[Menu]** button and use the direction buttons to select



Then, press the **[Enter]** button.

2. Use the direction buttons to select the timeout value and press the **[Enter]** button.



Privacy Option

You can set a password to prevent unauthorised access to your phone's functions.

1. Press the **[Menu]** button and use the direction buttons to select



Then, press the **[Enter]** button.

2. Enter the password, and select [Save]
 - To clear a password, enter the password and select [Clear].

Reset Configuration

To delete all saved data (Phone Book and Messages) and return the phone to its default configuration settings:

1. Press the **[Menu]** button and use the direction buttons to select



Then, press the **[Enter]** button.

2. Enter the phone's password and press **[Enter]** to reset.

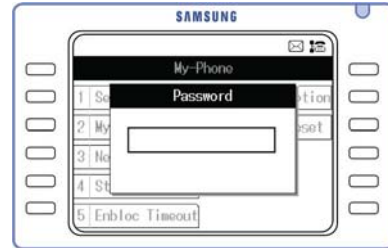

Caution: Take care when using this feature not to accidentally delete data you require.

Version Information

To view your phone's software version:

1. Press the **[Menu]** button and use the direction buttons to select



→ **[8. Version Info]**

Then, press the **[Enter]** button.

Samsung Telecoms (U.K.) Limited
Brookside Business Park, Greengate, Middleton, Manchester M24 1GS

